

¡Juguemos con las Matemáticas!



La edición del Cuaderno de trabajo 2 “**Juguemos con las Matemáticas**” fue elaborado y revisado por personal técnico de la Secretaría de Educación de Honduras.

Presidencia de la República

Secretaría de Estado en el Despacho de Educación

Sub Secretaría de Asuntos Técnico Pedagógicos

Sub Secretaría de Asuntos Administrativos y Financieros

Unidad de Educación Prebásica

Editores (2005)

Luz María Figueroa
Nilda Evelicia Oliva
Héctor Ámilcar Bardales

Diagramación (2005)

Arlin McCarthy
Daniel Alberto Orellana
Victor A. Moncada

Equipo Revisor (2014)

Ángela Rosibel Moreno
Héctor Ámilcar Bardales Inestroza
José Manuel Flores Zambrano
Mayra Ibelis Valdez García
María Verónica Castellanos
Rosa Sagrario López Escobar

Revisión técnico-gráfico

Departamento de Tecnología Educativa
Secretaría de Educación

© **Secretaría de Educación**

Comayagüela, M.D.C.
Tegucigalpa, Honduras, C. A.
Cuaderno de trabajo 2
“Juguemos con las Matemáticas”
Reimpresión año 2014
ISBN:

**Programa de Educación Primaria e Integración Tecnológica
Componente 1: “Ampliación de Cobertura en Educación Prebásica”**

Se prohíbe la reproducción total o parcial de este cuaderno por cualquier medio, sin el permiso por escrito de la Secretaría de Educación

DISTRIBUCIÓN GRATUITA-PROHIBIDA SU VENTA

POSICIÓN ARRIBA Y ABAJO

Colorea de anaranjado las sombrillas que tienen el bastón hacia arriba y de morado las sombrillas que tienen el bastón hacia abajo.

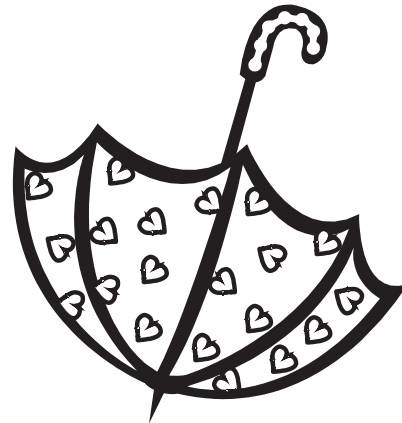
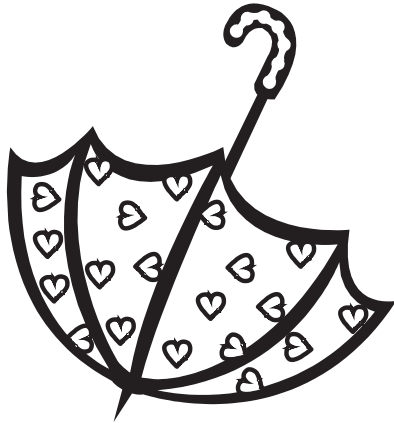
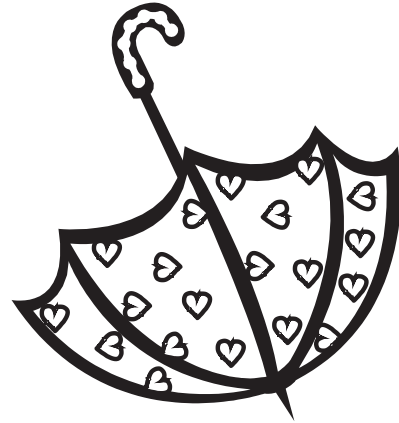

ALTO Y BAJO

Observa y mide las figuras y colorea las figuras altas.

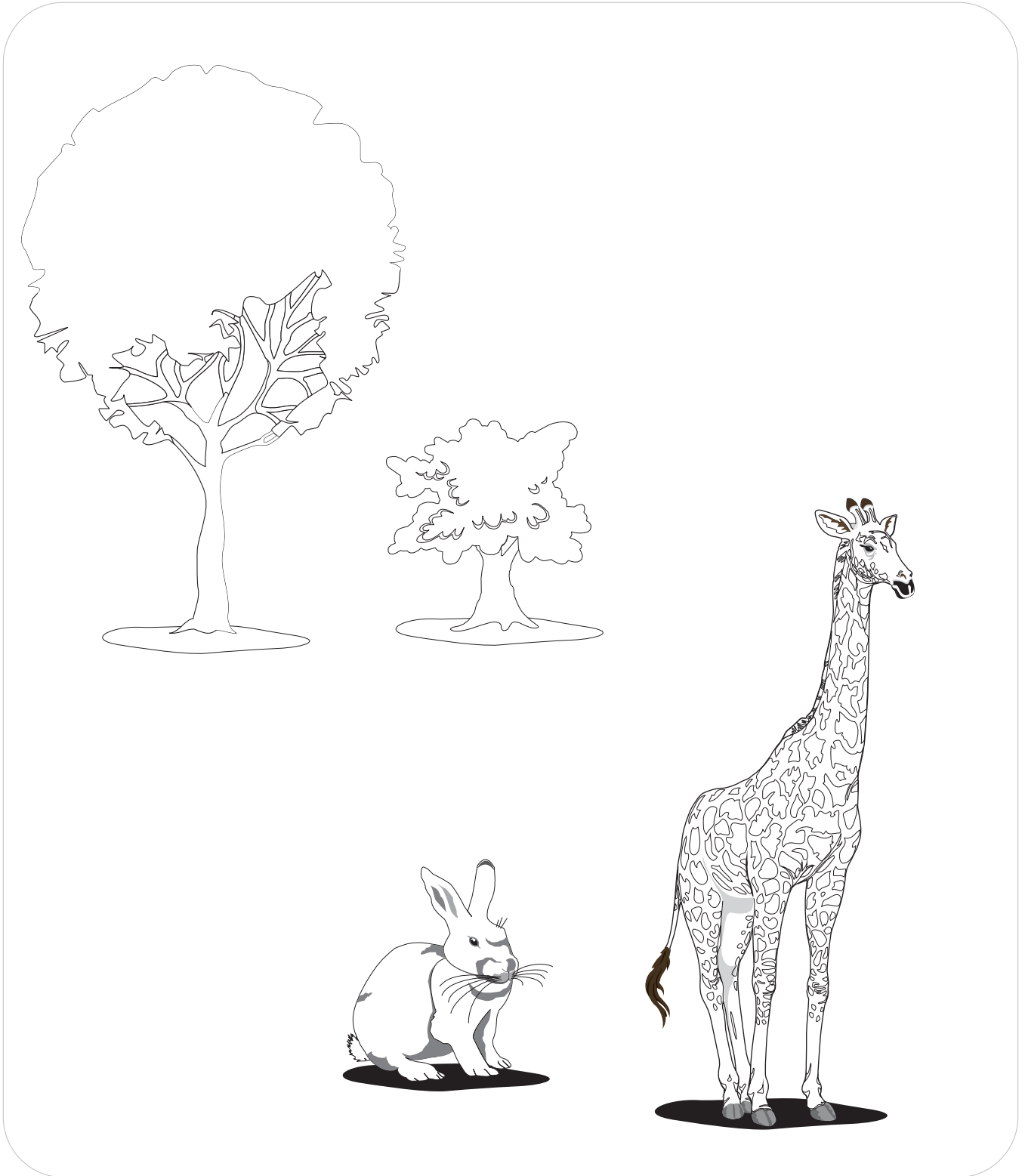

DENTRO Y FUERA

Colorea los animales que están dentro de:

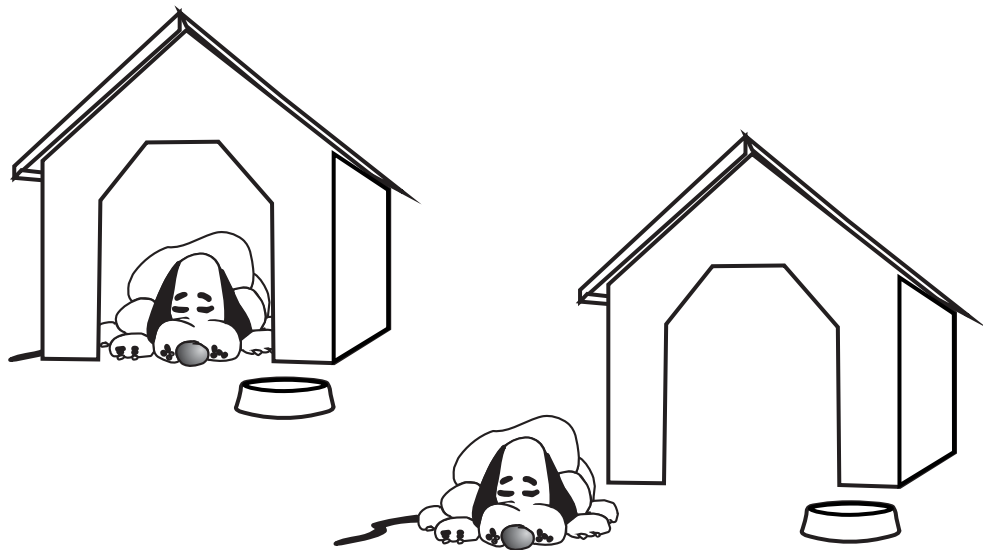
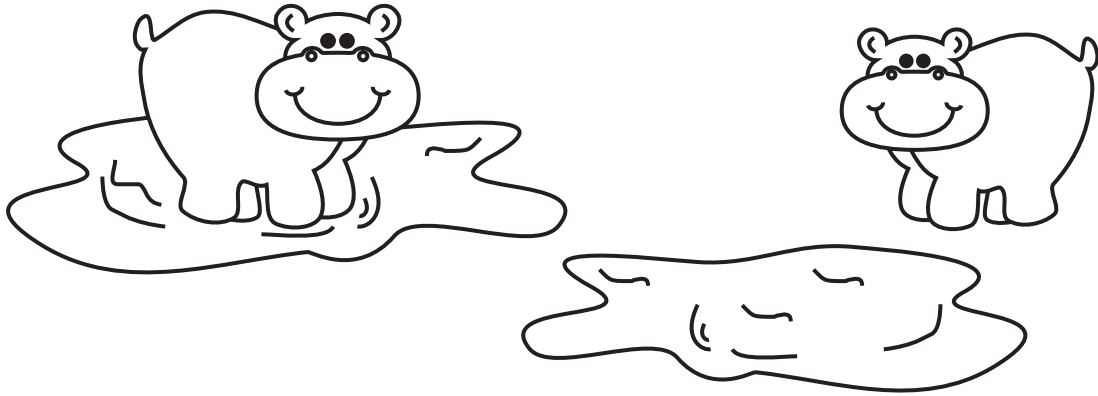

Actividad RELACIONES ESPACIALES, DERECHA E IZQUIERDA

Colorea de verde las figuras que señalan hacia la izquierda y de anaranjado las que señalan a la derecha.

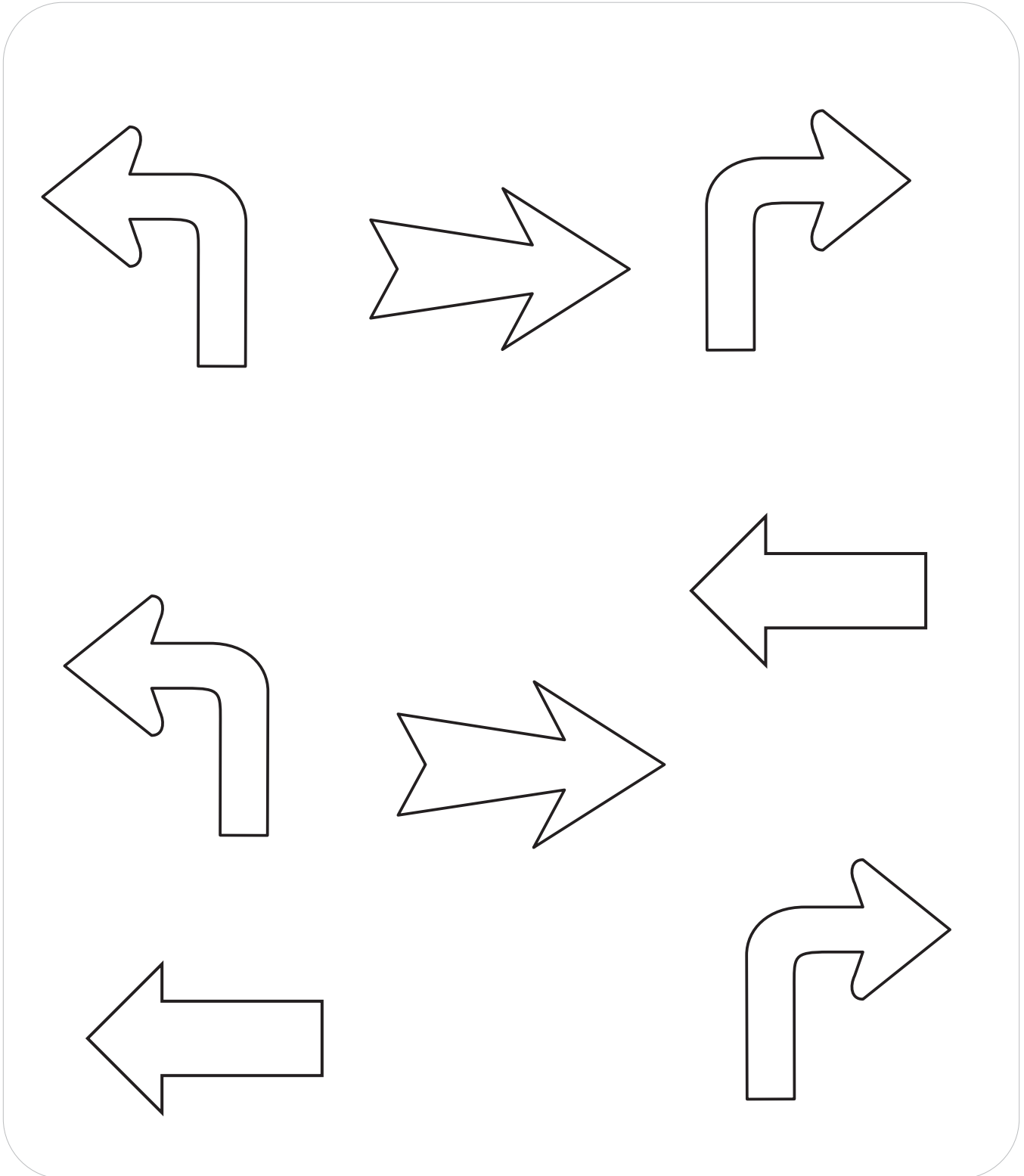

Repasa los conceptos frío, caliente, día, noche, encendido, apagado, une con una línea lo opuesto de cada dibujo.

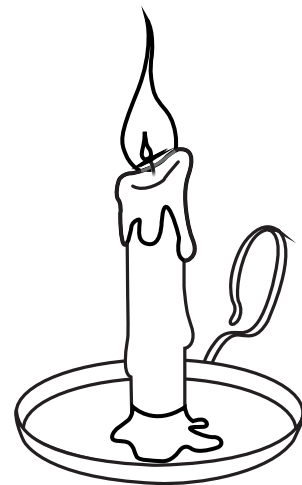
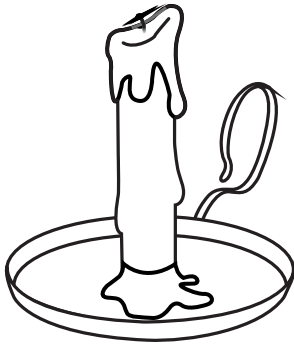
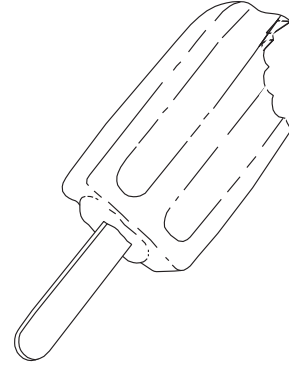
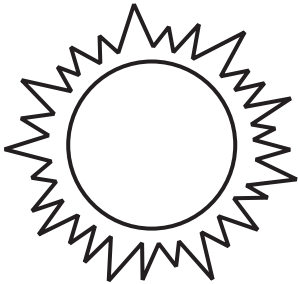

Identifica en los dibujos los conceptos de arriba, abajo, fuera, dentro, mucho, nada, lento, rápido. Luego une los dibujos opuestos.

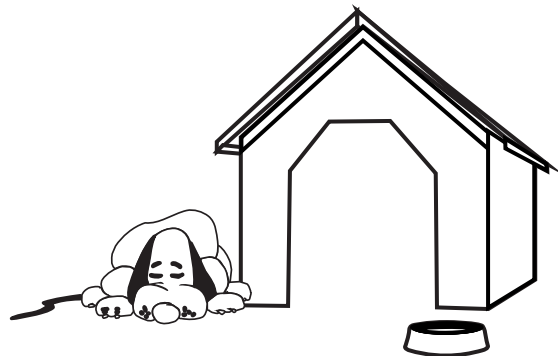
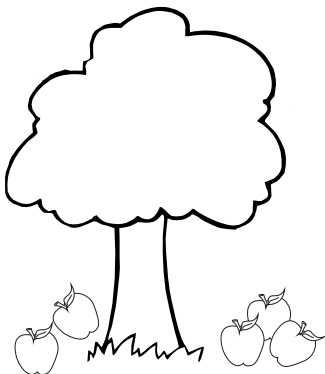
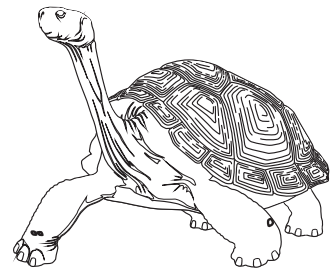
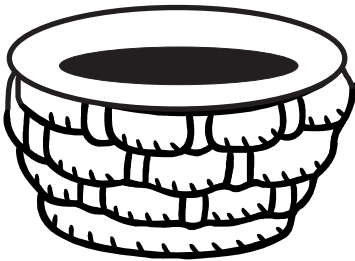
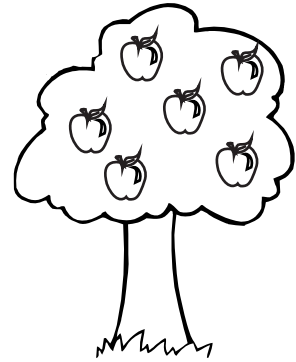

FIGURAS IGUALES

Colorea y une con una línea las figuras que son iguales.

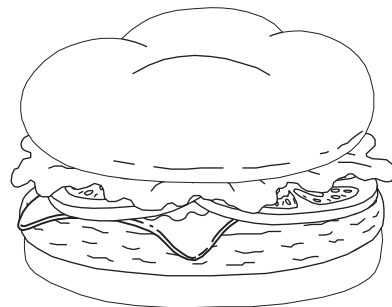
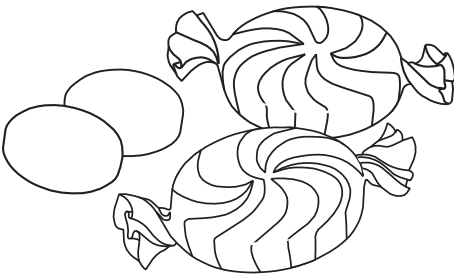
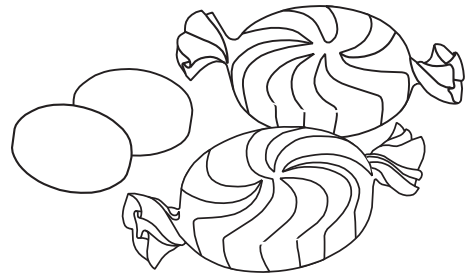
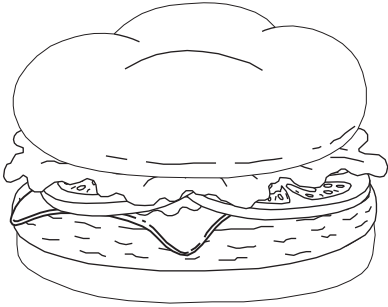

Colorea y une con una línea los dibujos que son semejantes.

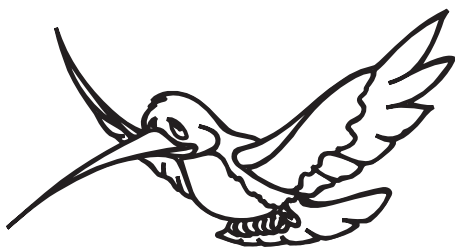
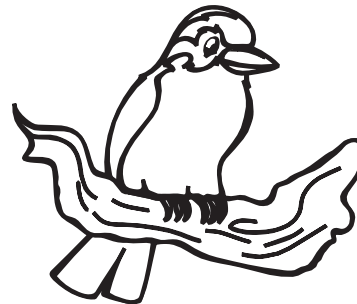
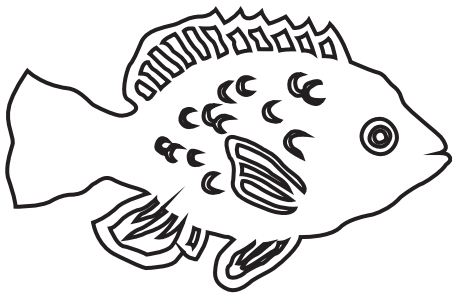

GRANDE Y PEQUEÑO

Identifica las figuras y encierra en un círculo las pequeñas.



LARGO Y CORTO

Observa las figuras, realiza mediciones. Identifique cuál es corto y cuál es largo, colorea de rojo el largo y de azul el corto.

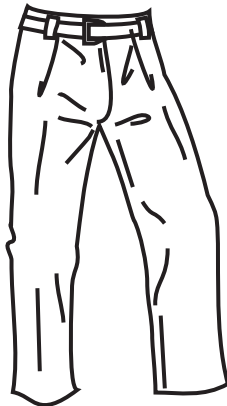
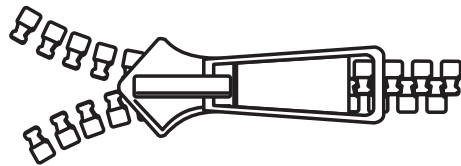
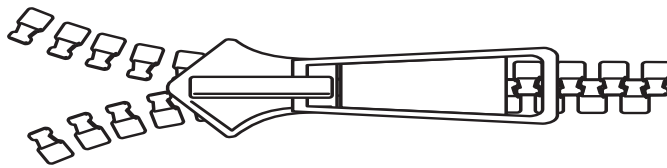
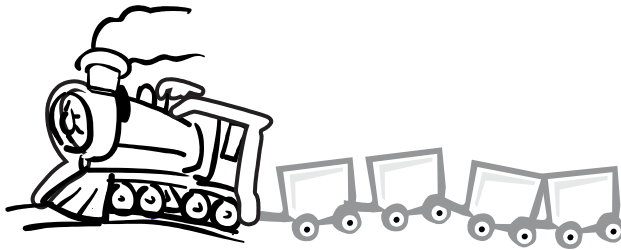
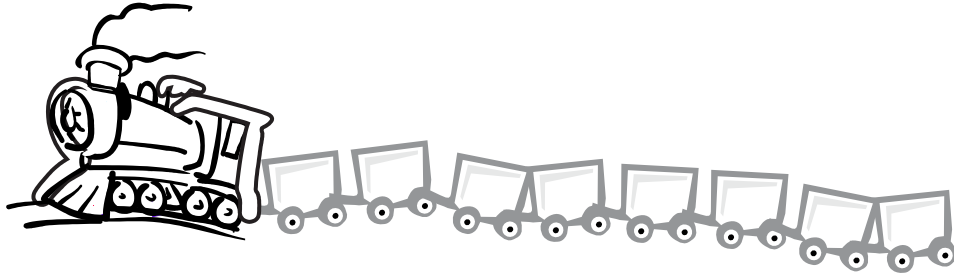

RELACIÓN DE OBJETOS

Observa e identifica cada uno de los objetos que se te presentan en la ilustración, une con una línea según se relacionen.

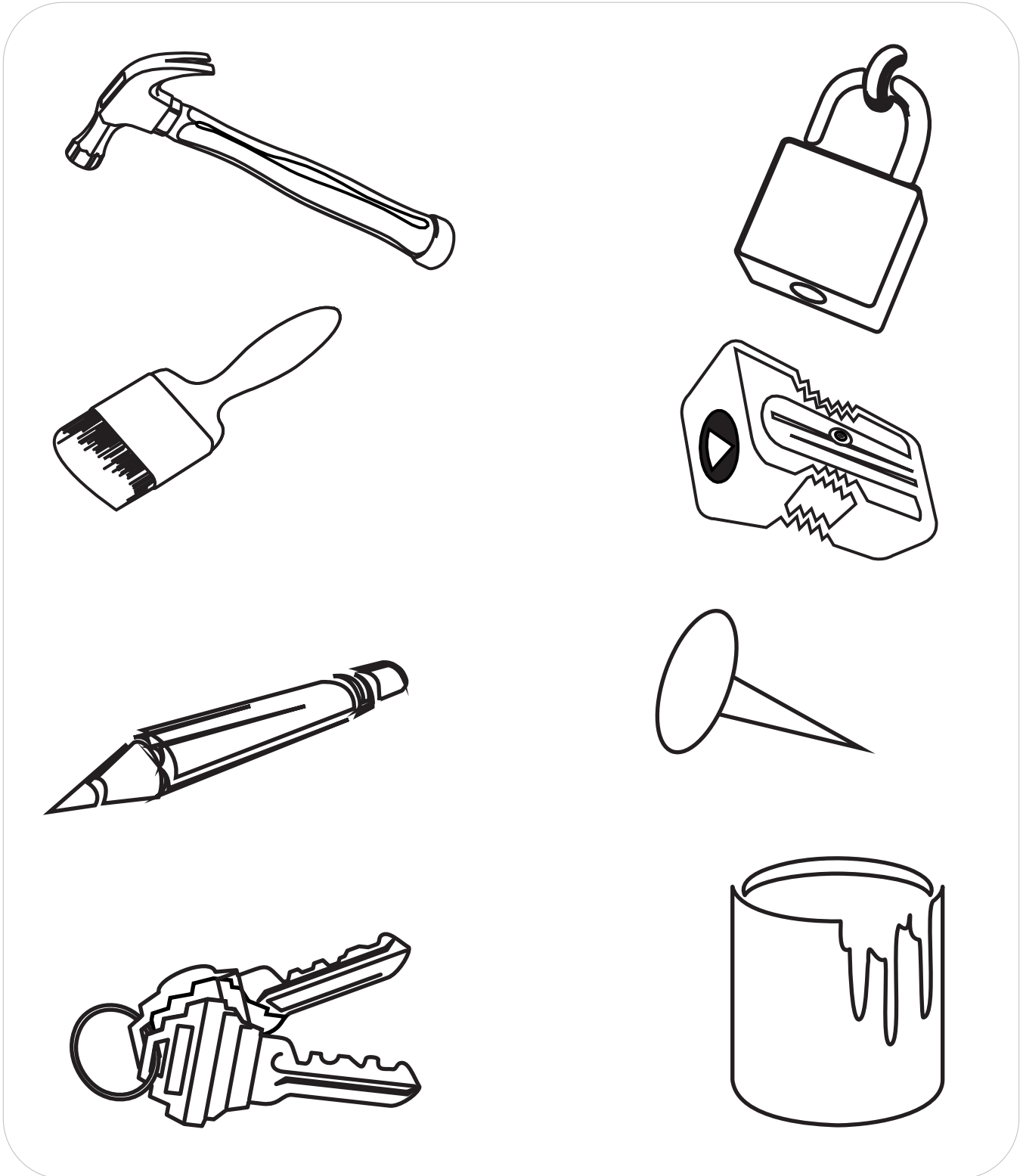

ENCIMA Y DEBAJO

Identifica lo que está encima y lo que está debajo, colorea lo que está encima.

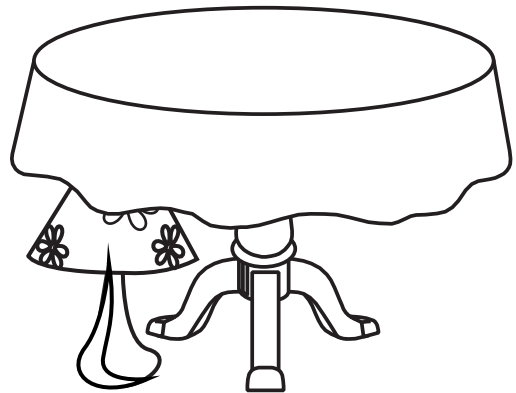
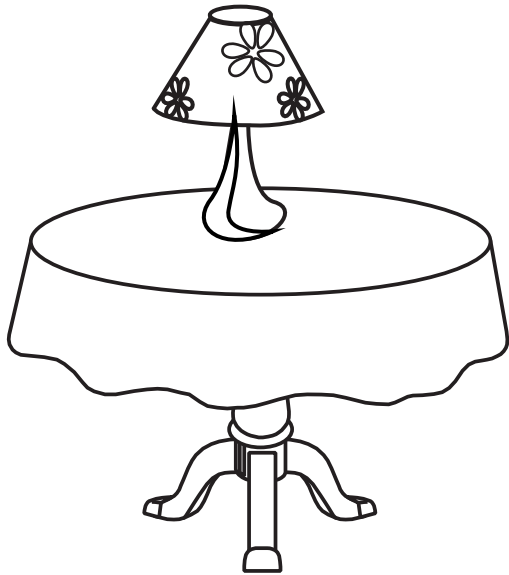

GRUESO Y DELGADO

Identifica cuáles de las figuras son gruesas y cuáles delgadas, y colorea las figuras gruesas de color rojo.

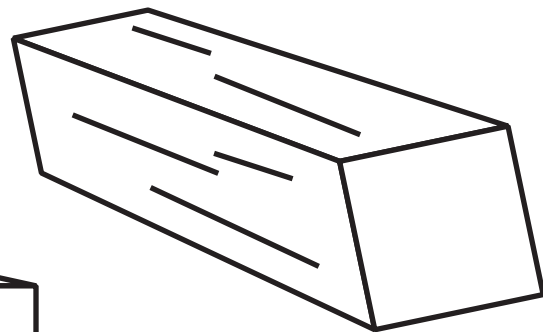
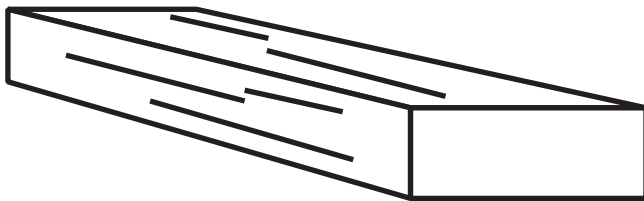
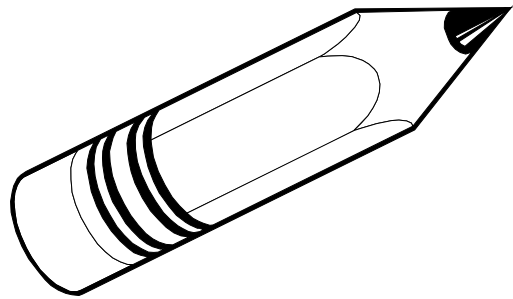
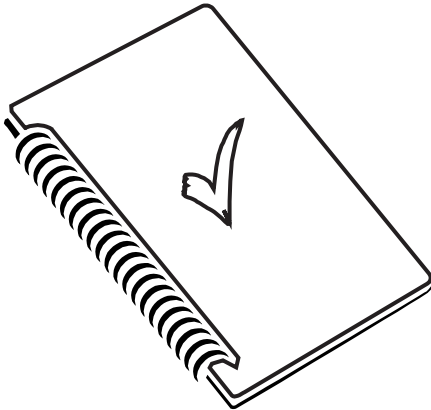
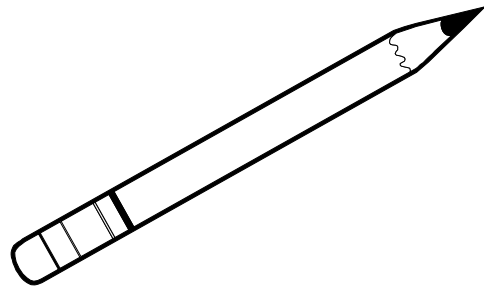
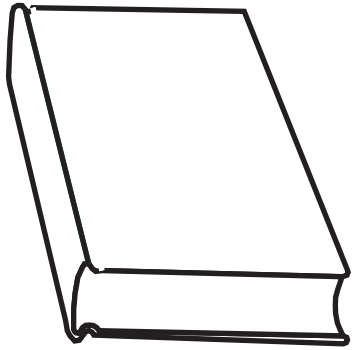

EL TRIÁNGULO

Coloca las huellas de tu dedo índice en el interior del triángulo utilizando pintura de dedo.

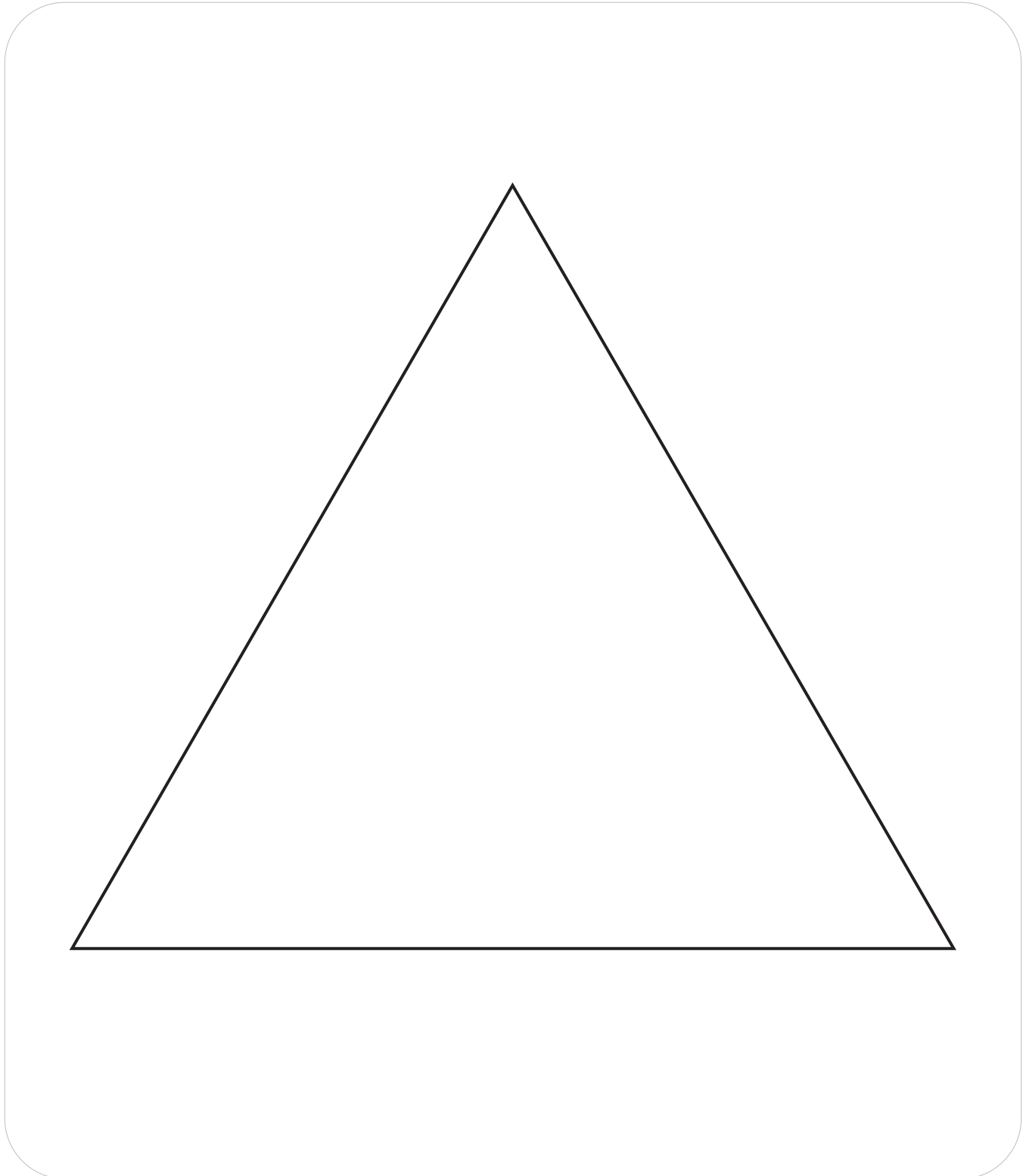

ESCRIBE EL NÚMERO UNO

Realiza los siguientes ejercicios del 1 al 15 siguiendo la dirección de las flechas.

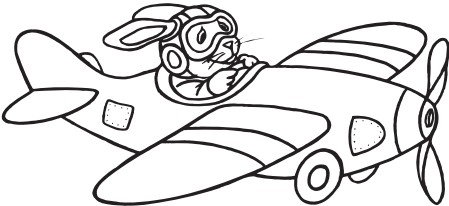
<h1>1</h1>										
Uno										
1	1	1	1	1	1	1	1	1	1	1

1										
---	--	--	--	--	--	--	--	--	--	--

--	--	--	--	--	--	--	--	--	--	--

--	--	--	--	--	--	--	--	--	--	--

ESCRIBE EL NÚMERO DOS

2

Dos

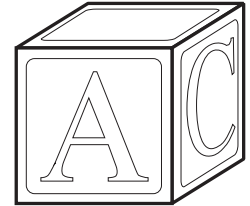
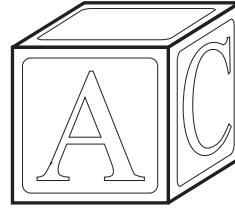

2	2	2	2	2	2	2	2	2	2	2
---	---	---	---	---	---	---	---	---	---	---

2										
---	--	--	--	--	--	--	--	--	--	--

--	--	--	--	--	--	--	--	--	--	--

--	--	--	--	--	--	--	--	--	--	--

CUADRADO

Pega papel troceado en el contorno de la figura del cuadrado.

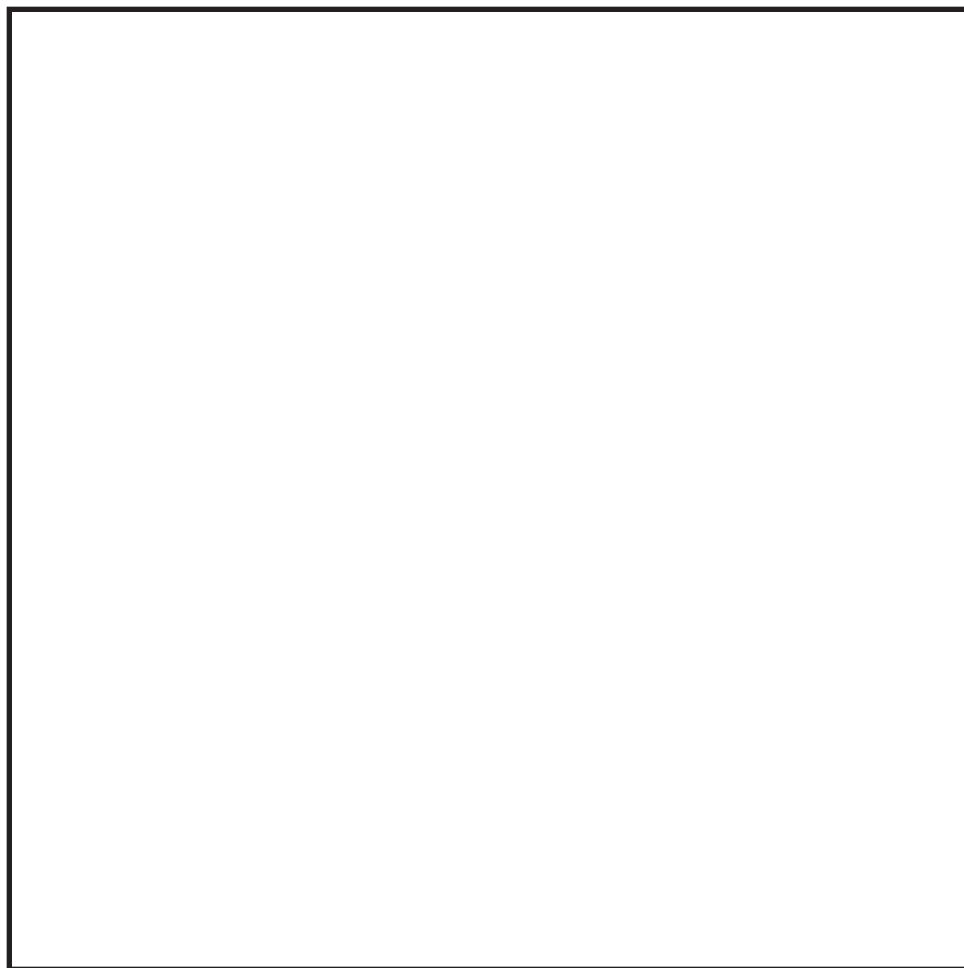

ROMBO

Identifica los lados, ángulos y el vértice de la figura geométrica.

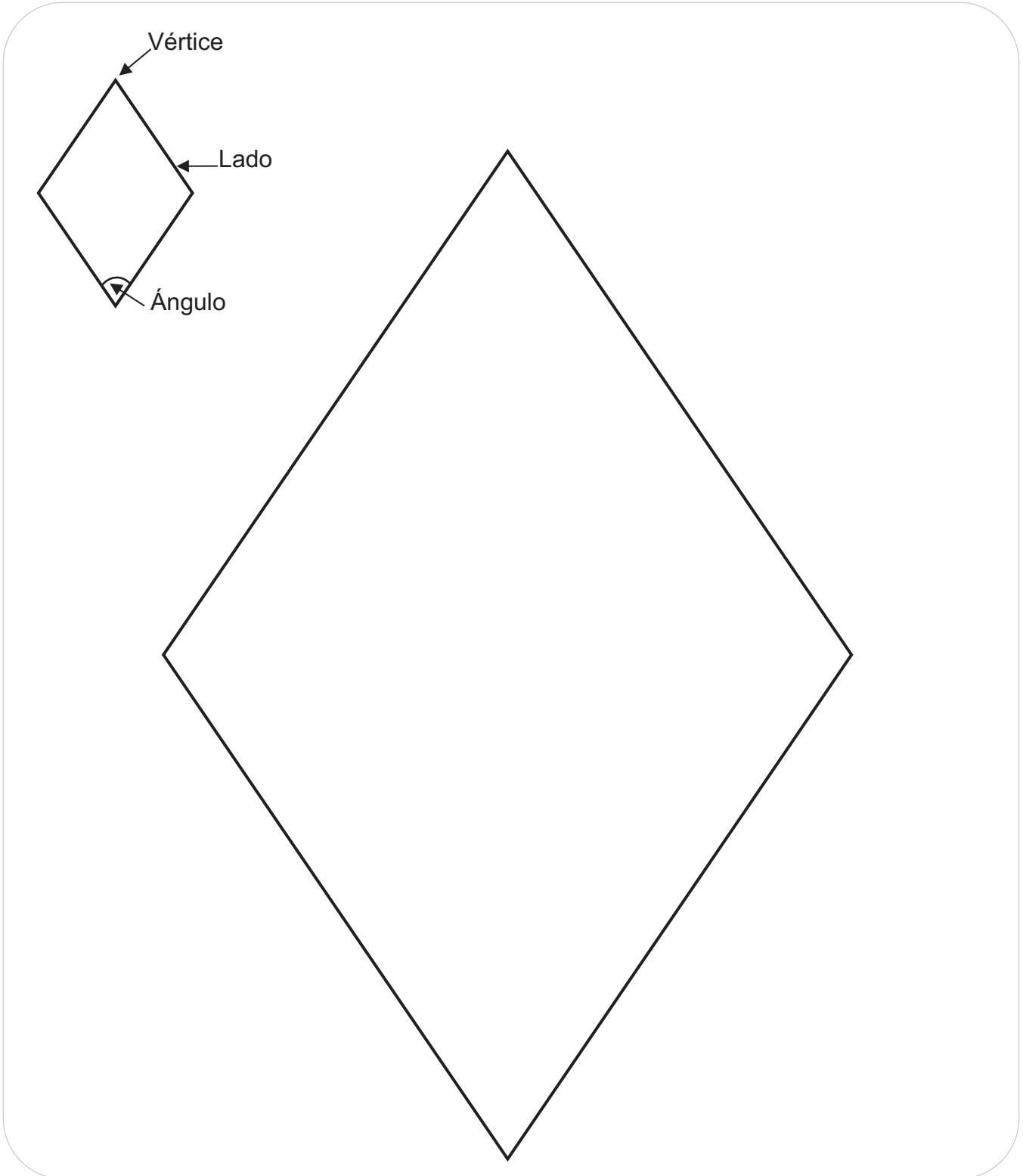

RECTÁNGULO

Colorea de amarillo, el interior del rectángulo, siguiendo la dirección de izquierda a derecha.

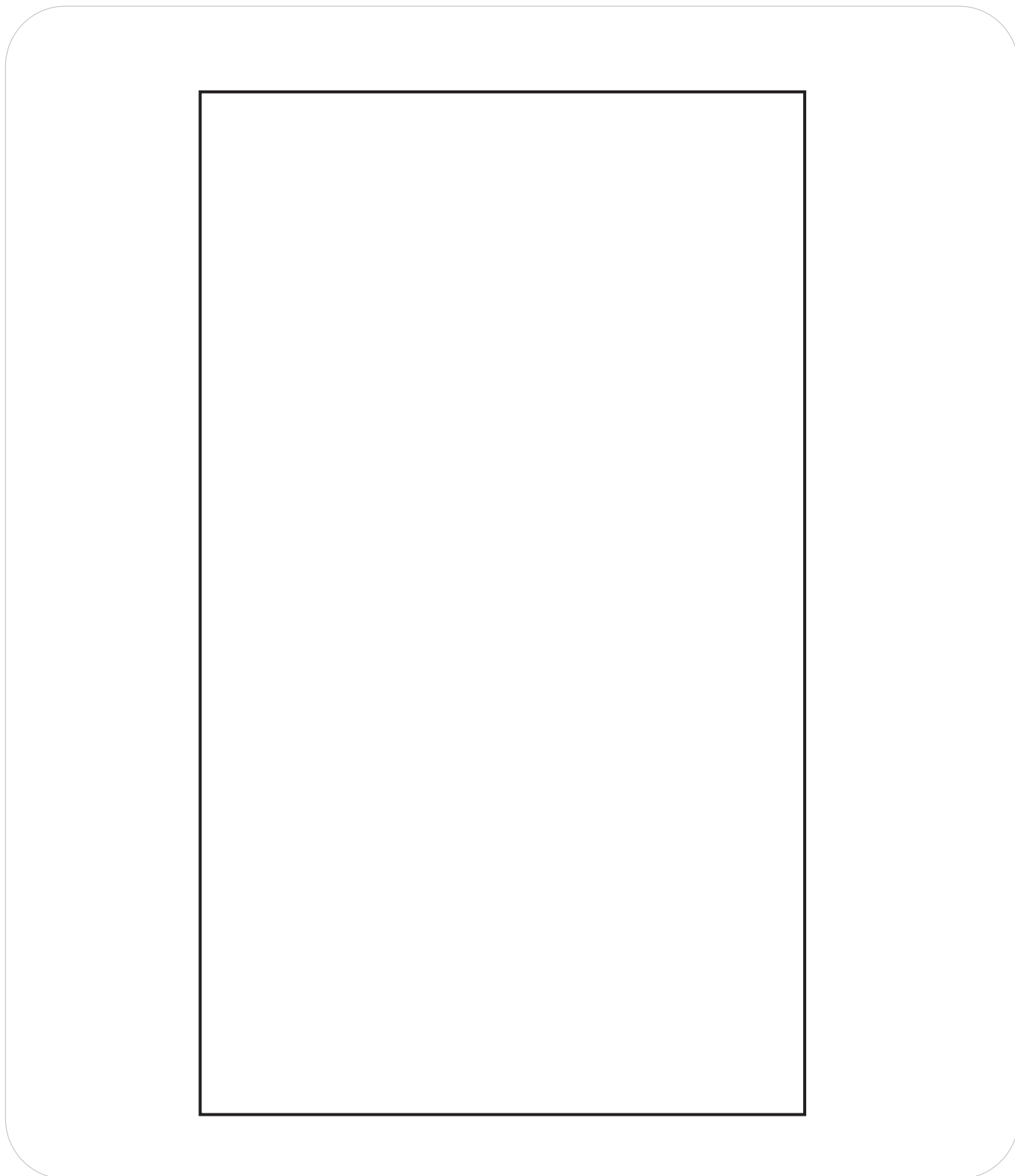

ESCRIBE EL NÚMERO TRES

3

Tres



3	3	3	3	3	3	3	3	3	3	3
---	---	---	---	---	---	---	---	---	---	---

3										
---	--	--	--	--	--	--	--	--	--	--

--	--	--	--	--	--	--	--	--	--	--

--	--	--	--	--	--	--	--	--	--	--

ESCRIBE EL NÚMERO CUATRO

4

Cuatro

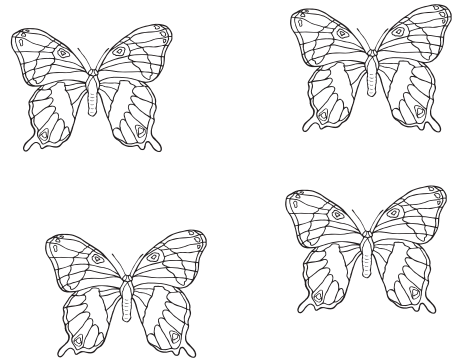

4 ↑	4	4	4	4	4	4	4	4	4	4
-----	---	---	---	---	---	---	---	---	---	---

4 ↑										
-----	--	--	--	--	--	--	--	--	--	--

--	--	--	--	--	--	--	--	--	--	--

--	--	--	--	--	--	--	--	--	--	--

LLENO Y VACÍO

Observa los dibujos e identifica los conceptos lleno y vacío. Colorea las figuras vacías.

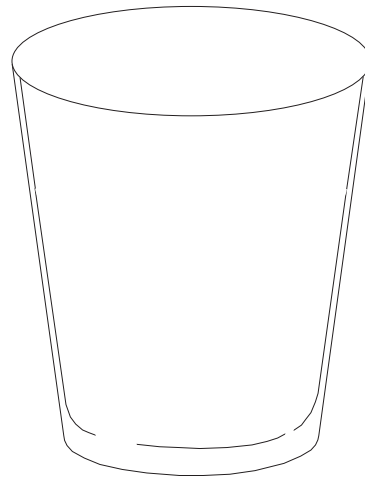
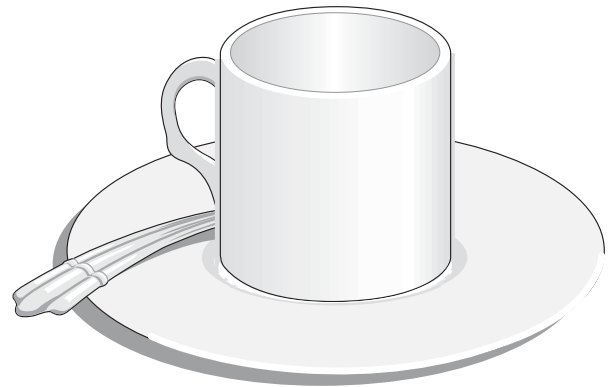

ESCRIBE EL NÚMERO CINCO

5

Cinco

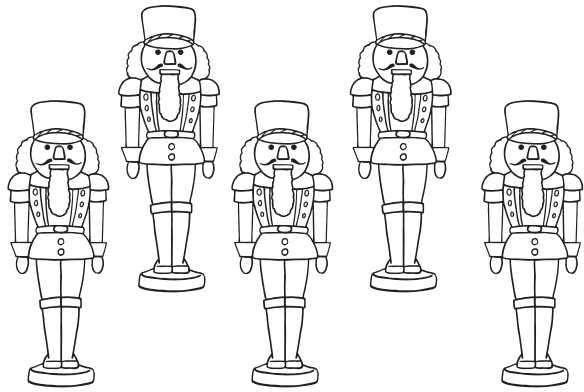

5	5	5	5	5	5	5	5	5	5	5
---	---	---	---	---	---	---	---	---	---	---

5										
---	--	--	--	--	--	--	--	--	--	--

--	--	--	--	--	--	--	--	--	--	--

--	--	--	--	--	--	--	--	--	--	--

EL CIRCULO

Utilizando la técnica de retorcido pega un cordón de papel crepe color verde en la circunferencia del Círculo.

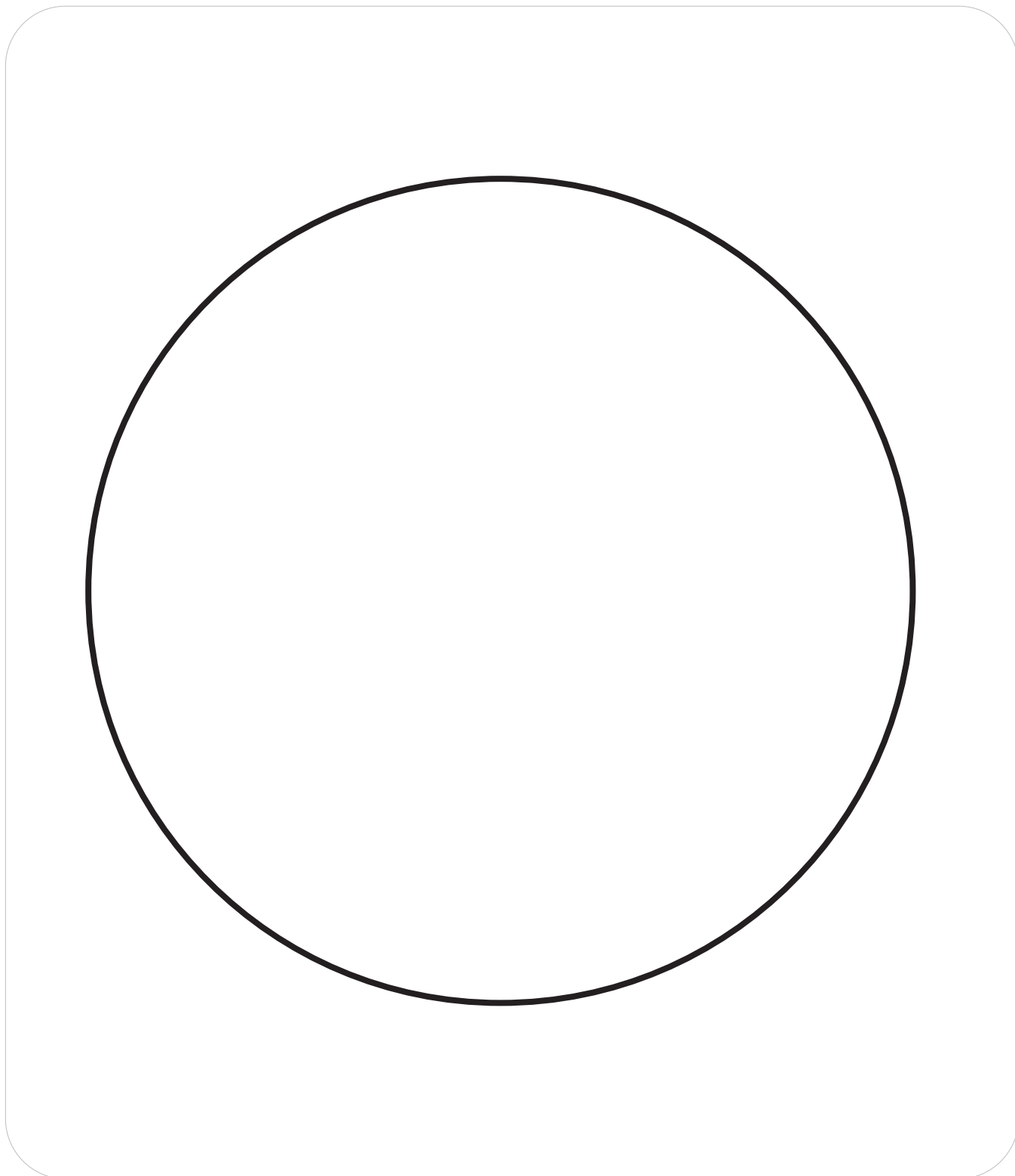

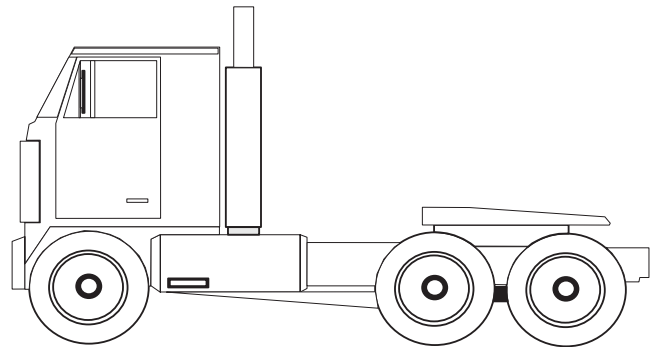
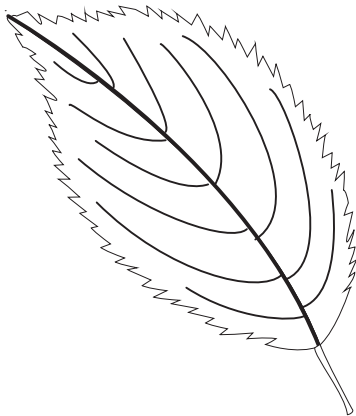
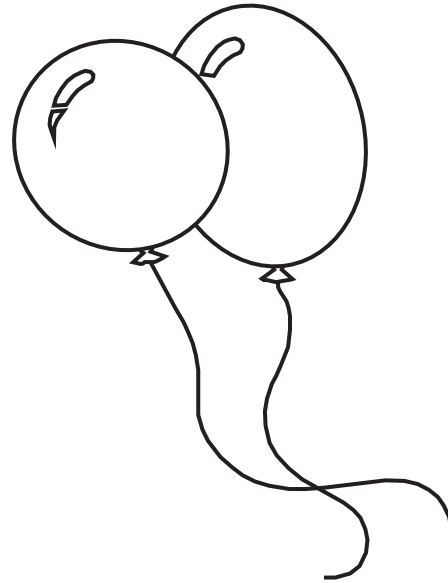

LIVIANO Y PESADO

Observa los dibujos, define cuáles tienen más peso y cuales tienen menor peso. Encierra en un círculo los que pesan más y colorea los que pesan menos.

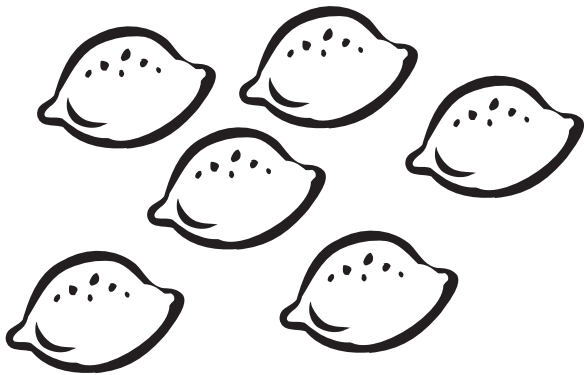

ESCRIBE EL NÚMERO SEIS

												
	Seis											
	6	6	6	6	6	6	6	6	6	6	6	6

												
--	--	--	--	--	--	--	--	--	--	--	--	--

--	--	--	--	--	--	--	--	--	--	--	--	--

--	--	--	--	--	--	--	--	--	--	--	--	--

EL ÓVALO

Identifica dentro del aula y en otros materiales objetos de forma ovalada, puntea el interior de la figura del óvalo.

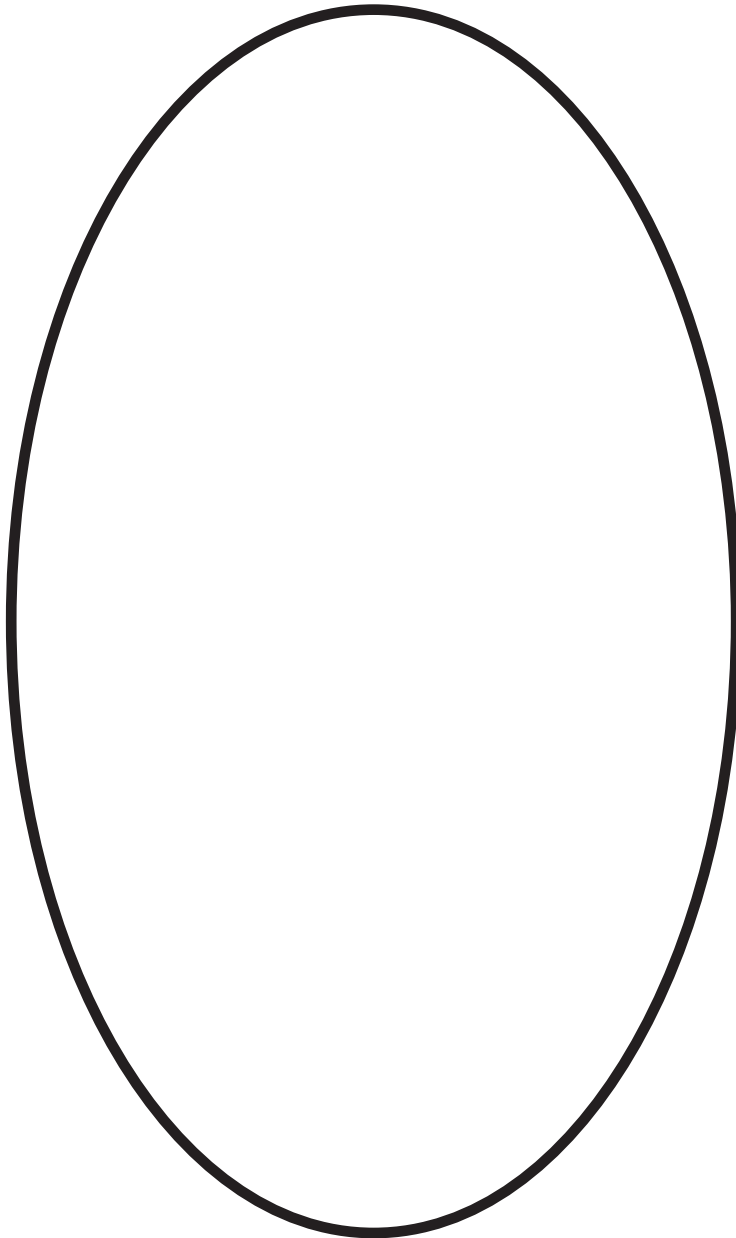

FIGURAS GEOMÉTRICAS

Observa los dibujos, comenta lo que esta cerca de la niña y lo que esta lejos.
Recorta las figuras geométrica y pegalas en la figura de arriba.

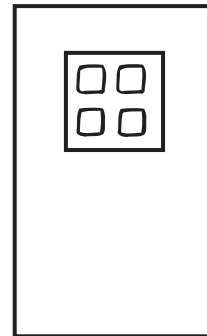
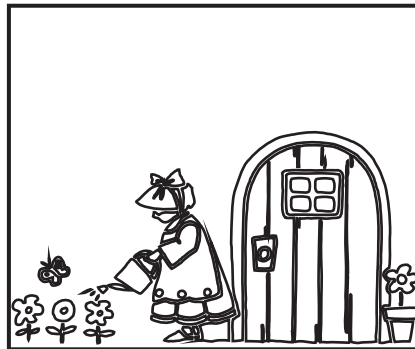
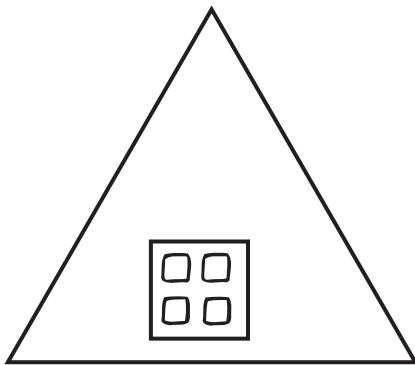
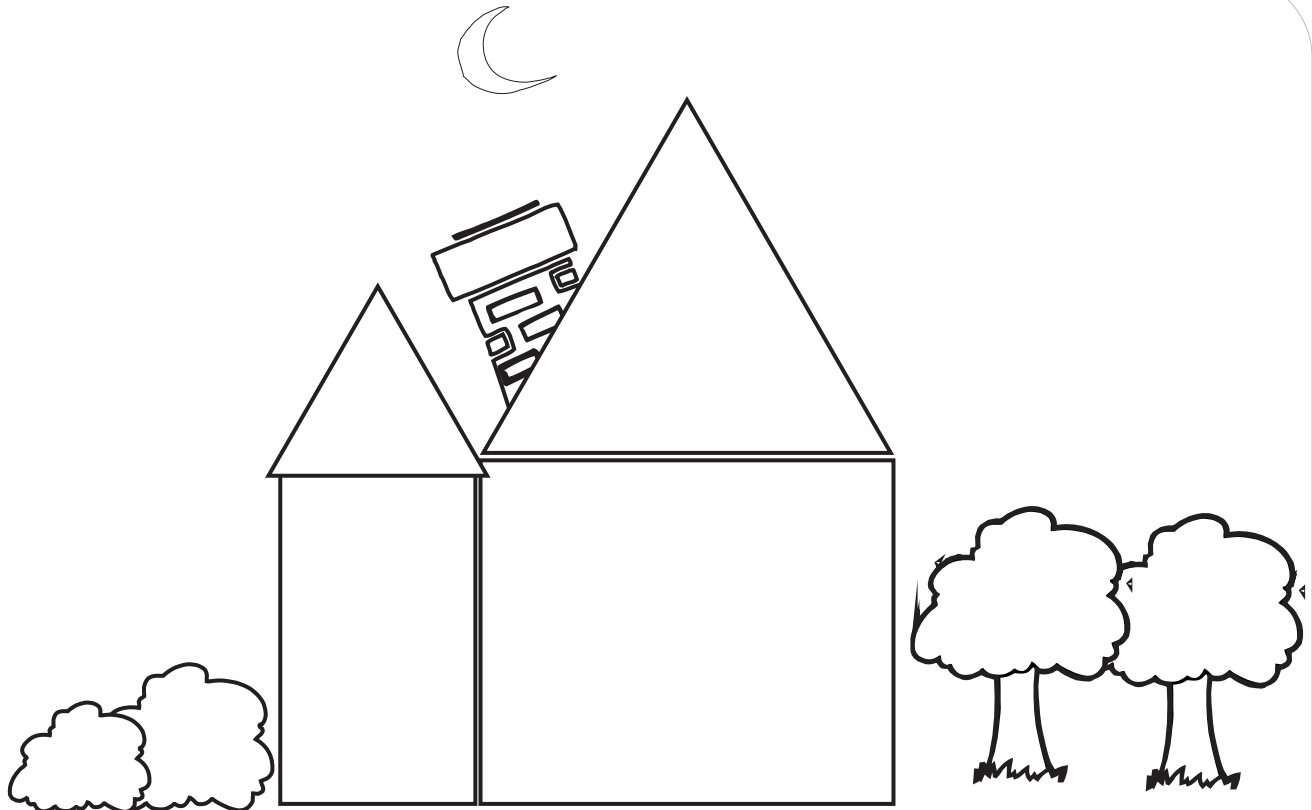

7

Siete

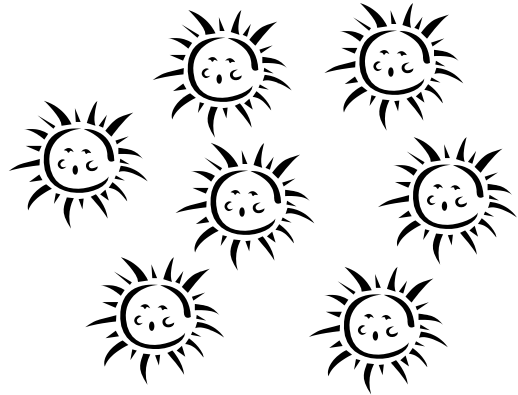

7	7	7	7	7	7	7	7	7	7	7
---	---	---	---	---	---	---	---	---	---	---

7										
---	--	--	--	--	--	--	--	--	--	--

--	--	--	--	--	--	--	--	--	--	--

--	--	--	--	--	--	--	--	--	--	--

ESCRIBE EL NÚMERO OCHO

8

Ocho



	8	8	8	8	8	8	8	8	8	8	8
--	---	---	---	---	---	---	---	---	---	---	---

--	--	--	--	--	--	--	--	--	--	--	--

--	--	--	--	--	--	--	--	--	--	--	--







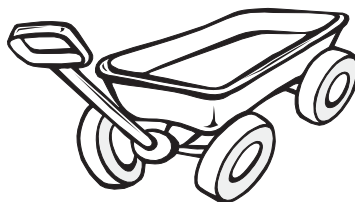
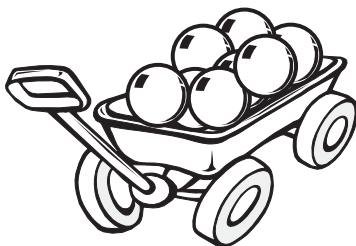
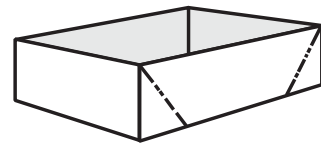
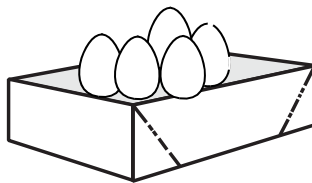
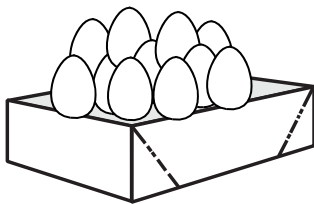
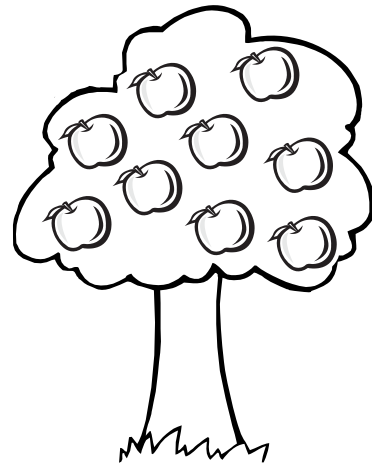
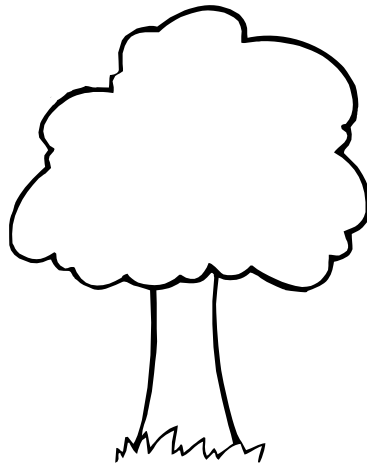
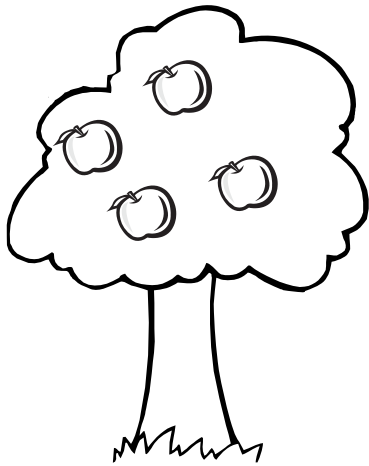



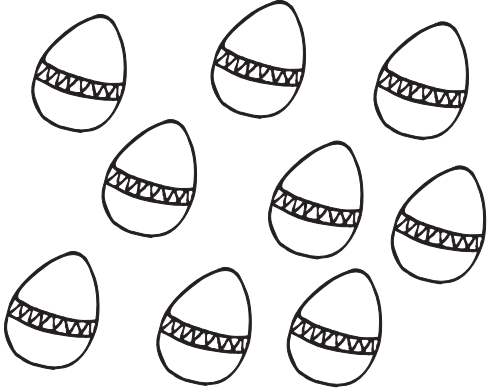

--	--	--	--	--	--	--	--	--	--	--	--

MUCHO, POCO Y NADA

Marca con una X las figuras que están vacías, colorea los que tienen muchos elementos y encierra en un círculo los que tienen pocos elementos.



ESCRIBE EL NÚMERO NUEVE

										
Nueve										
										

										
--	--	--	--	--	--	--	--	--	--	--

--	--	--	--	--	--	--	--	--	--	--

--	--	--	--	--	--	--	--	--	--	--

10

Diez

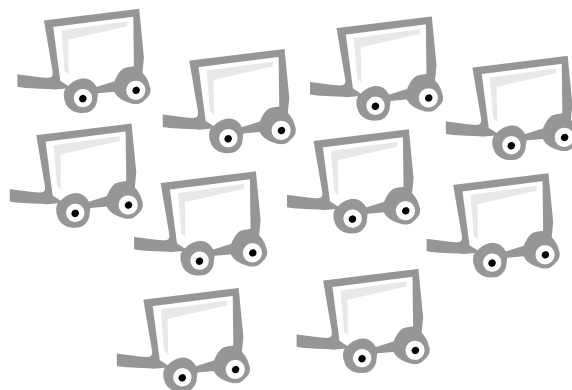

↗10	10	10	10	10	10	10	10	10	10	10
-----	----	----	----	----	----	----	----	----	----	----

↗10										
-----	--	--	--	--	--	--	--	--	--	--

--	--	--	--	--	--	--	--	--	--	--

--	--	--	--	--	--	--	--	--	--	--

MÁS QUE, MENOS QUE.

Cuenta los elementos de cada conjunto, colorea los que tienen más elementos.

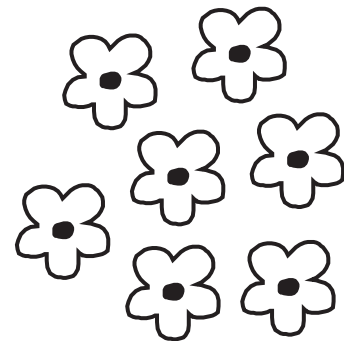
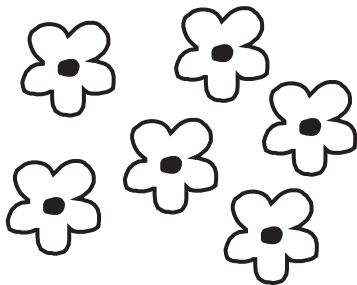
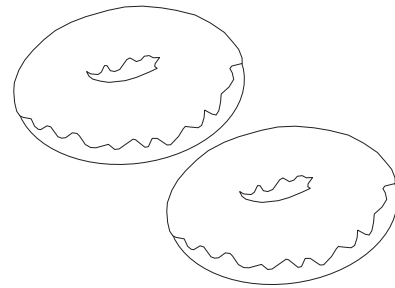
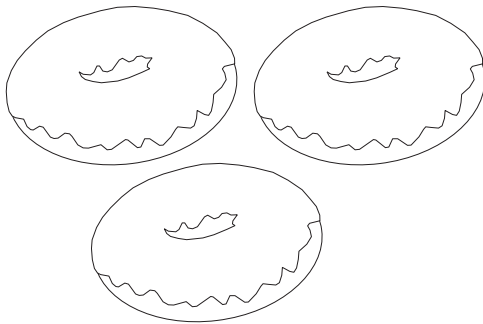
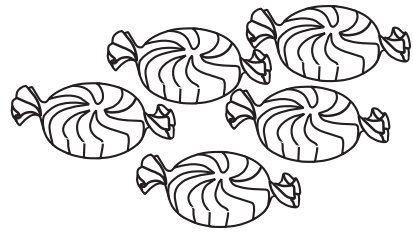
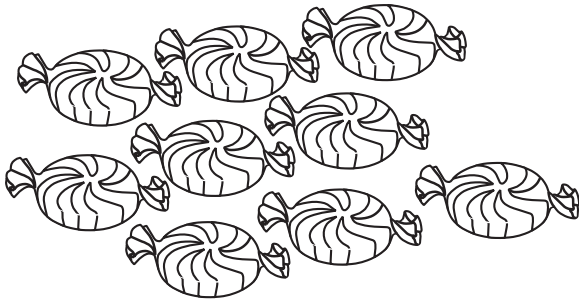

ESCRIBE EL NÚMERO ONCE

11

Once

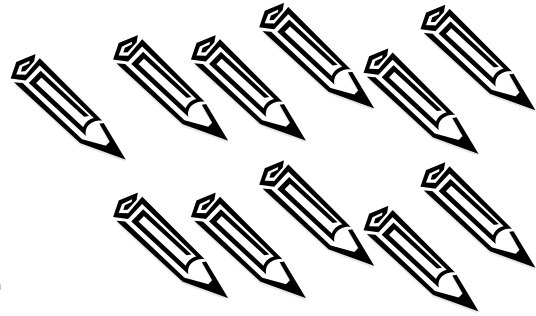

	11	11	11	11	11	11	11	11	11	11
--	----	----	----	----	----	----	----	----	----	----

--	--	--	--	--	--	--	--	--	--	--

--	--	--	--	--	--	--	--	--	--	--

--	--	--	--	--	--	--	--	--	--	--

LA MONEDA NACIONAL

Reconoce las monedas de circulación nacional y menciona su orden de mayor a menor valor.



ABIERTO Y CERRADO

Identifica el concepto de abierto y cerrado en las figuras. Encierra en un círculo las figuras que están abiertas.

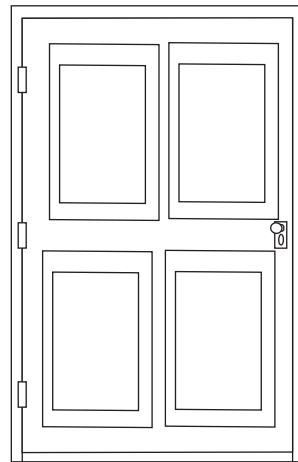
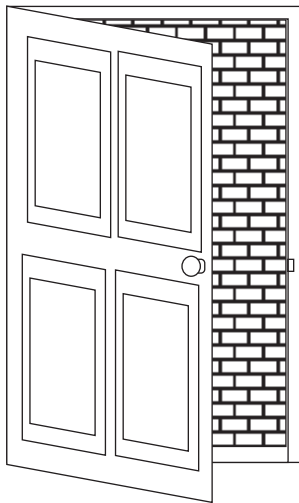
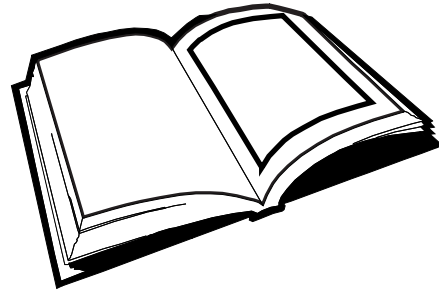
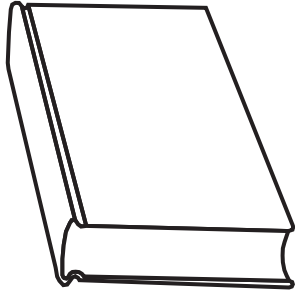

12

Doce



↗ 12	12	12	12	12	12	12	12	12	12	12
---------	----	----	----	----	----	----	----	----	----	----

↗ 12										
---------	--	--	--	--	--	--	--	--	--	--

--	--	--	--	--	--	--	--	--	--	--

--	--	--	--	--	--	--	--	--	--	--

Observa las figuras y colorea las enteras.

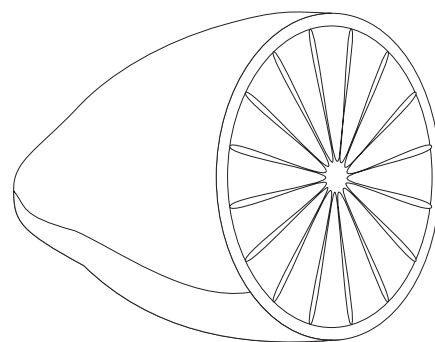
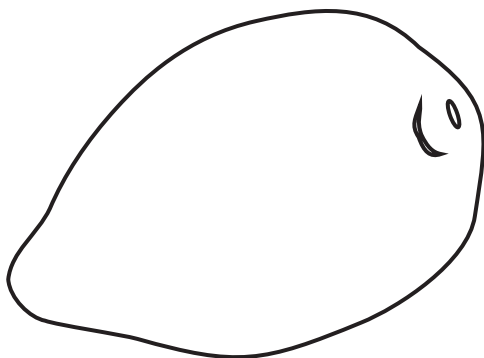
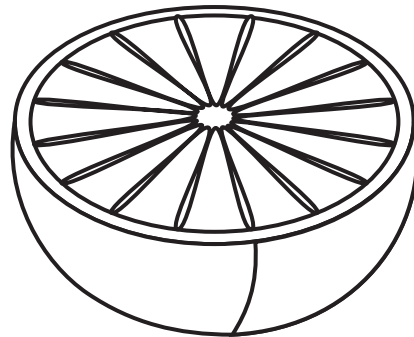
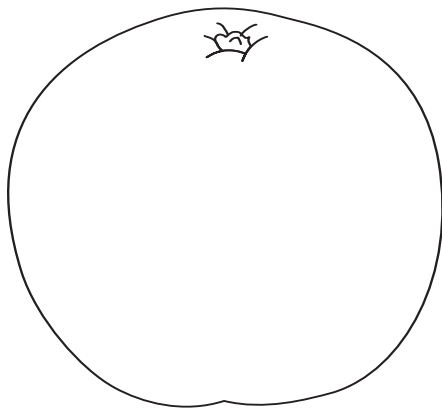
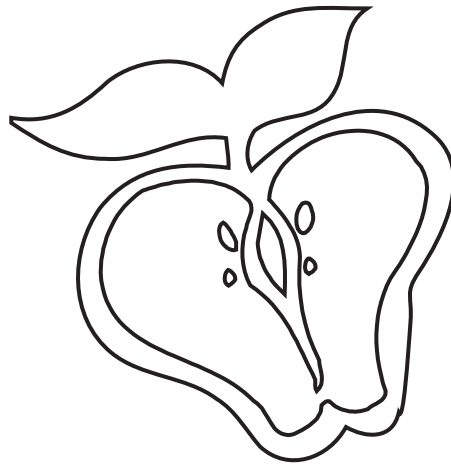
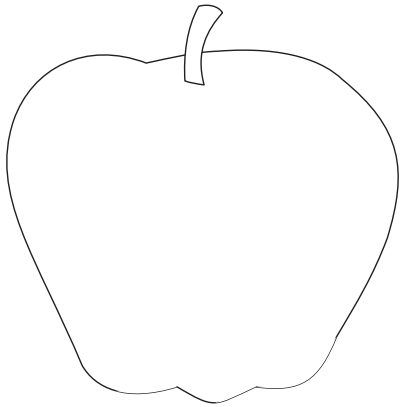

FRACCIONES

Observa y comenta que indica cada figura. Colorea lo que indica la fracción.

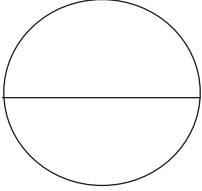
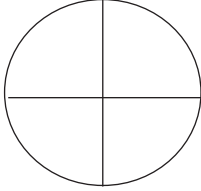
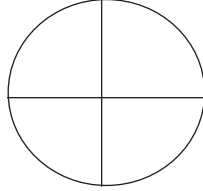
		
$\frac{1}{2}$	$\frac{1}{4}$	$\frac{2}{4}$

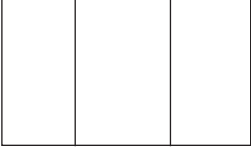
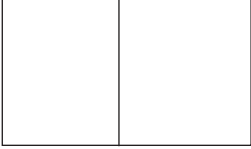
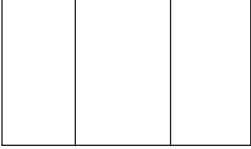
		
$\frac{1}{3}$	$\frac{1}{2}$	$\frac{2}{3}$

Divide las figuras según las fracciones que se te indique.

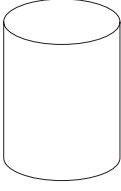
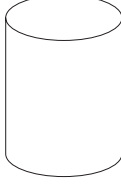
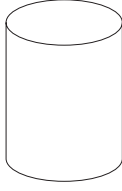
		
$\frac{1}{2}$	$\frac{1}{3}$	$\frac{2}{3}$

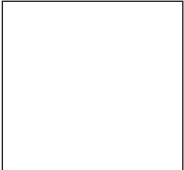
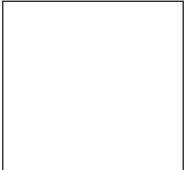
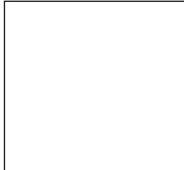
		
$\frac{1}{2}$	$\frac{1}{3}$	$\frac{2}{3}$

13

Trece

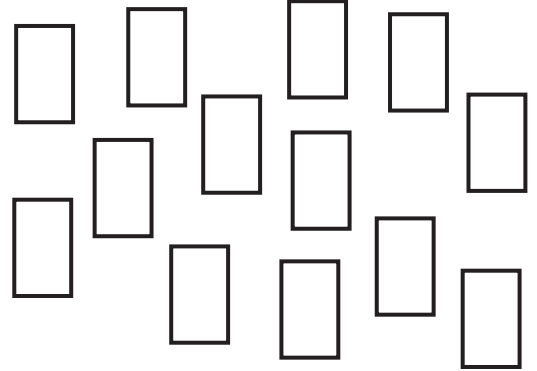

↑ 13	13	13	13	13	13	13	13	13	13	13
---------	----	----	----	----	----	----	----	----	----	----

↑ 13										
---------	--	--	--	--	--	--	--	--	--	--

--	--	--	--	--	--	--	--	--	--	--

--	--	--	--	--	--	--	--	--	--	--

En los recuadros que aparecen debajo de cada figura, escribir el número de acuerdo al orden de mayor a menor.

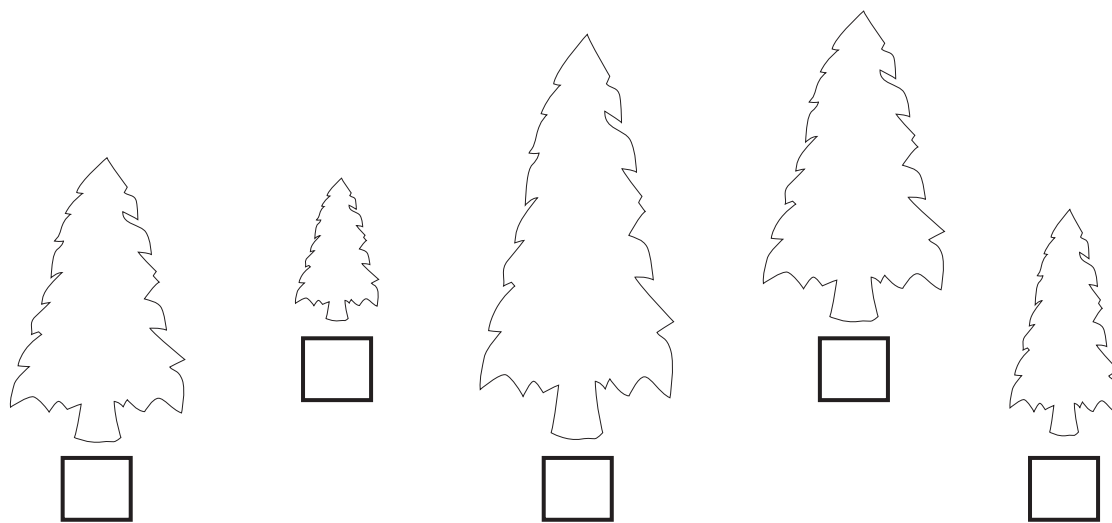
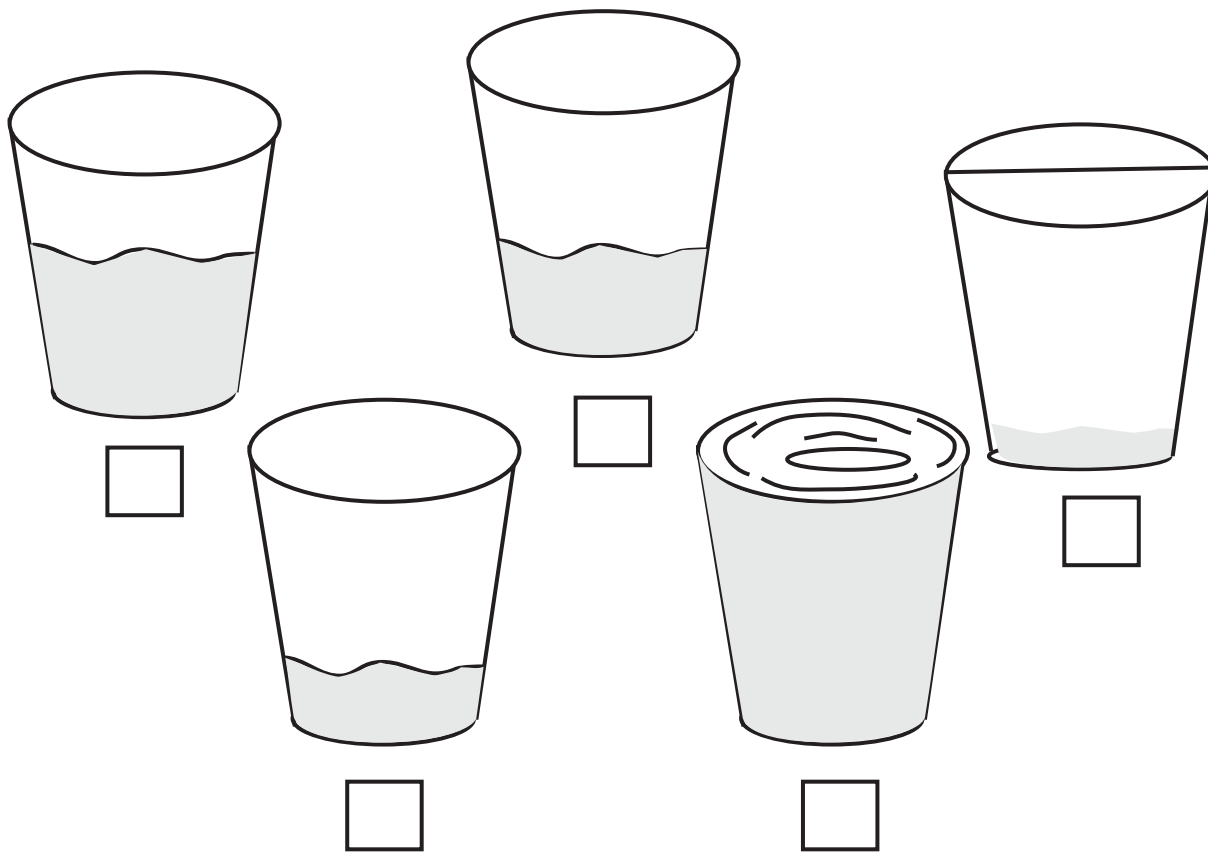

Observa las figuras, colorea las que tienen el mismo tamaño que la primera.

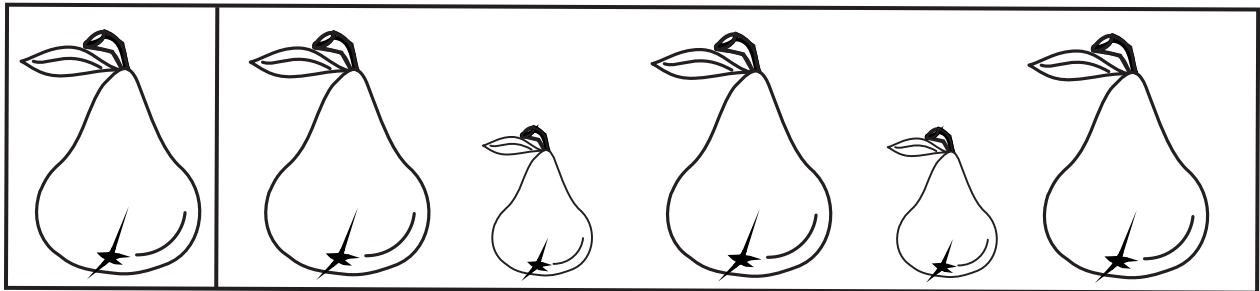
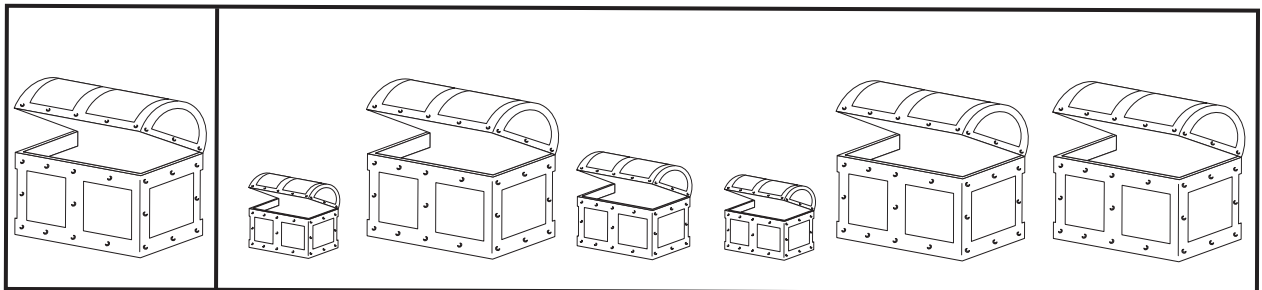
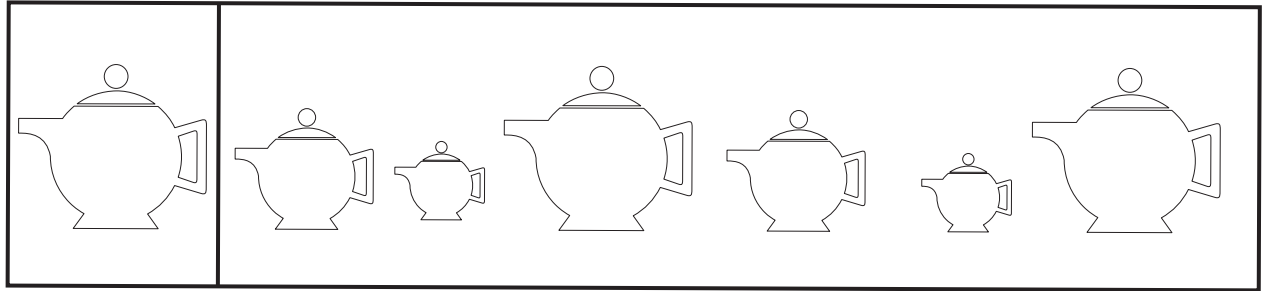

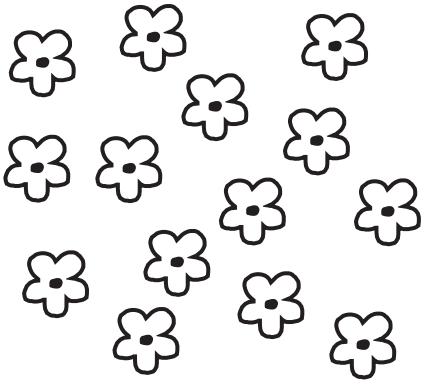
<h1>14</h1>										
										
14	14	14	14	14	14	14	14	14	14	14

14										
-----------	--	--	--	--	--	--	--	--	--	--

--	--	--	--	--	--	--	--	--	--	--

--	--	--	--	--	--	--	--	--	--	--

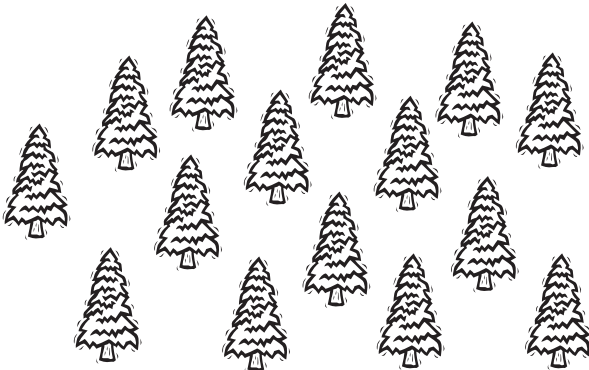
<h1>15</h1>											
Quince											
[↑] 15	15	15	15	15	15	15	15	15	15	15	15

[↑] 15											
-----------------	--	--	--	--	--	--	--	--	--	--	--

--	--	--	--	--	--	--	--	--	--	--	--

--	--	--	--	--	--	--	--	--	--	--	--

Pinta las figuras geométricas.

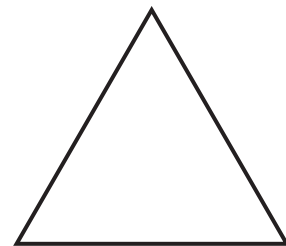
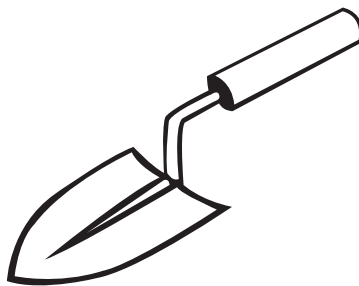
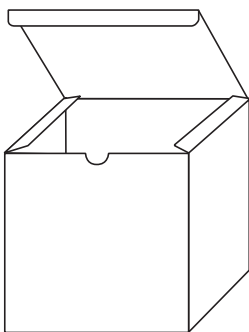
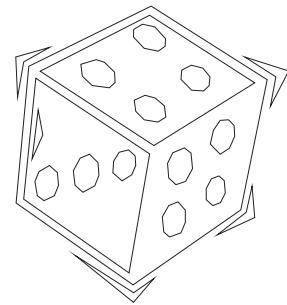
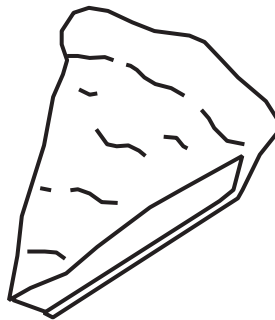
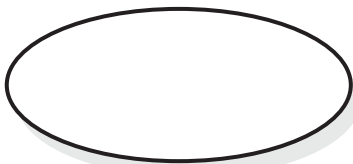
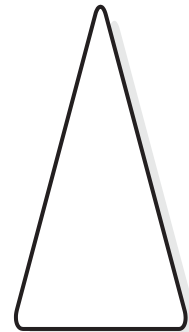
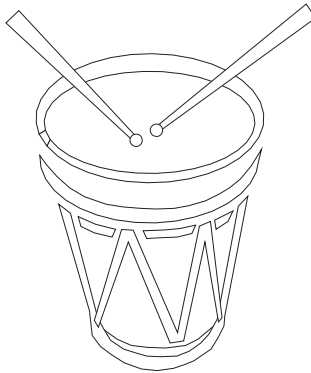
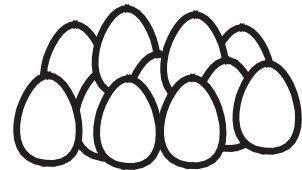
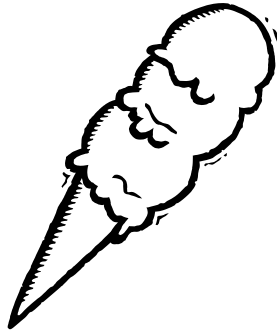
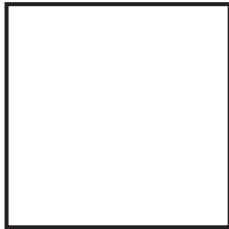

EL CILINDRO

Recorta la figura y construye un cilindro.

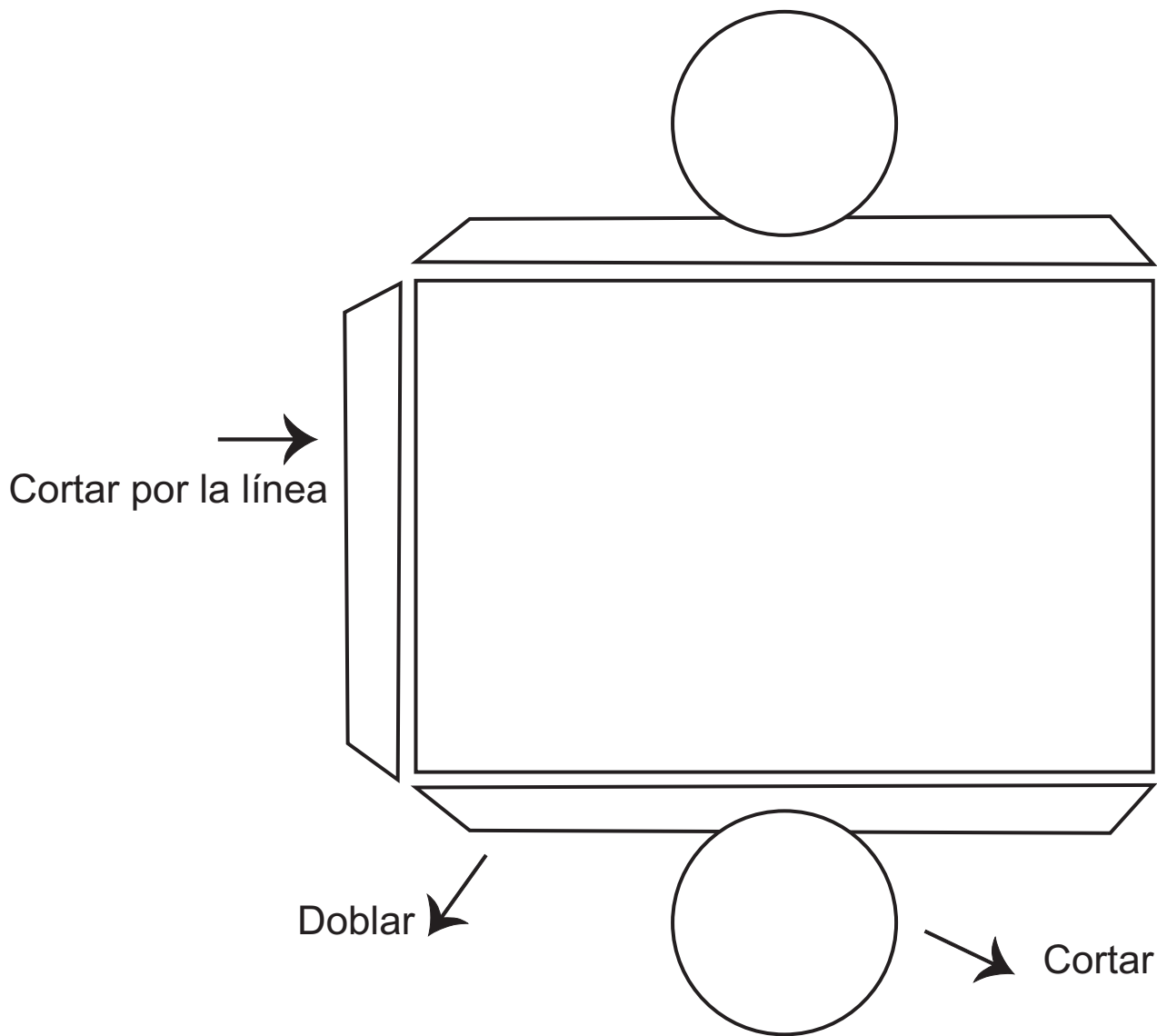

SÓLIDOS GEOMÉTRICOS

Colorea de diferente color las figuras de sólidos geométricos.

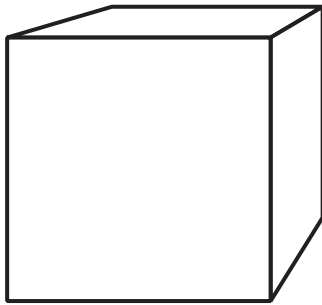

Cubo

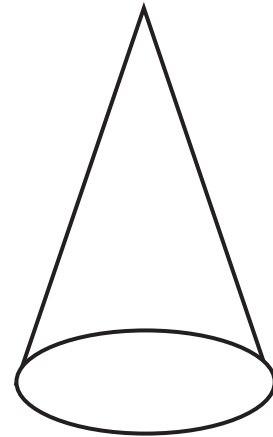

Cono

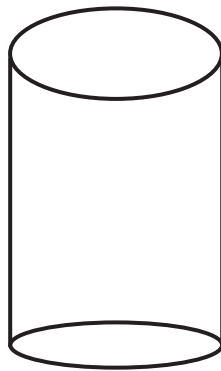

Cilíndro

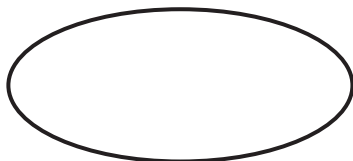

Óvalo

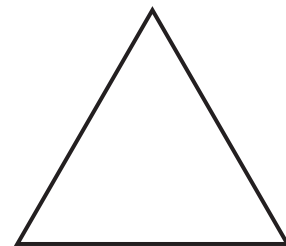

Triángulo

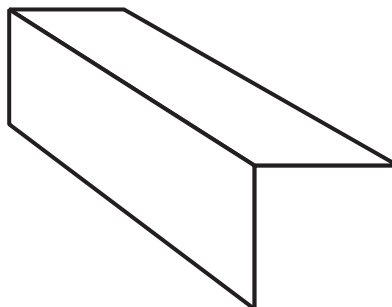

Prisma

COMPLETACIÓN

Observa y completa la secuencia trazando el número que hace falta.

0	1		3		5
---	---	--	---	--	---

6		8		10	
---	--	---	--	----	--

12		14	15		
----	--	----	----	--	--

	1		3		5
--	---	--	---	--	---

6		8		10	
---	--	---	--	----	--

12		14	15		
----	--	----	----	--	--

CORRESPONDENCIA

Une con una línea cada conjunto de figuras con el número que corresponde.



5



4



3

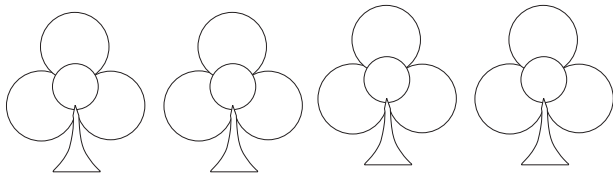

2

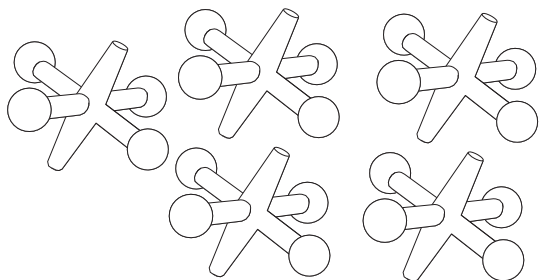

1

Une con una línea cada conjunto de figuras con el número que corresponde.

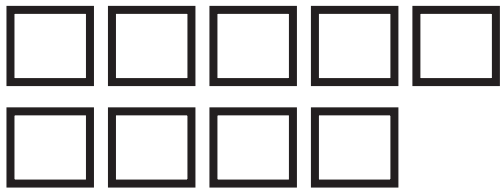

7

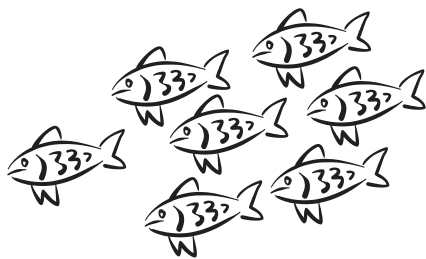

8

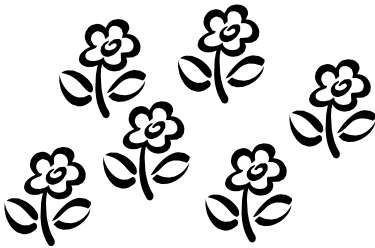

9

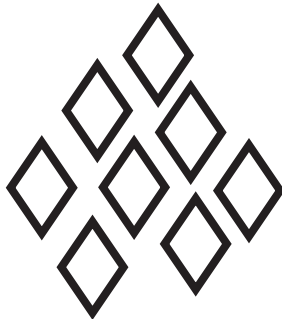

10

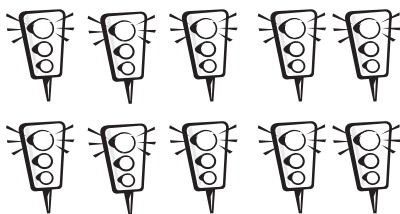

6

CUENTA

Cuenta los elementos de cada conjunto de figuras y escribe en el recuadro el número correspondiente.

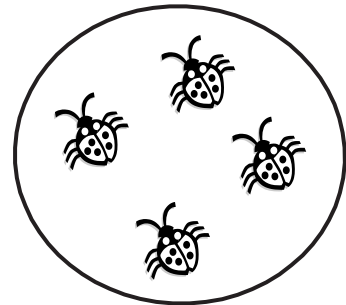
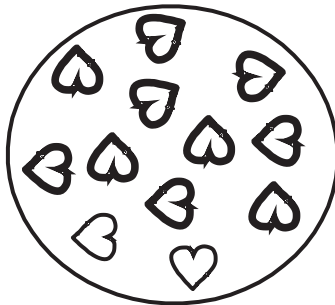
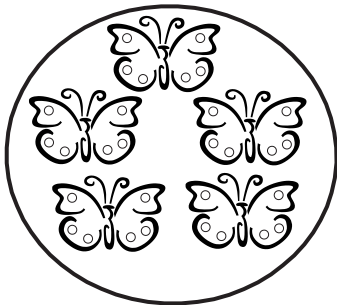
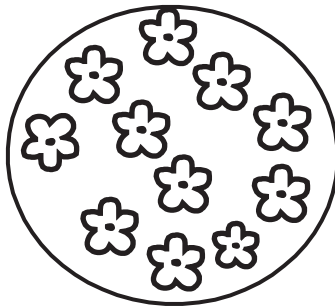
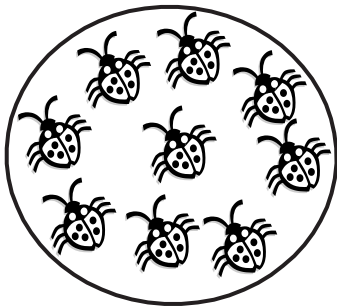
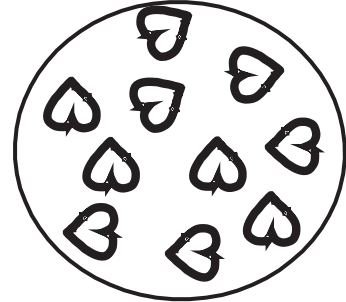
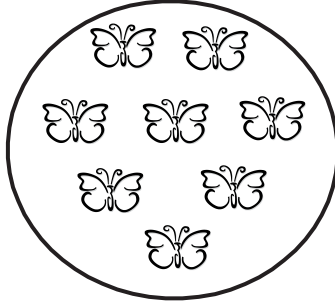
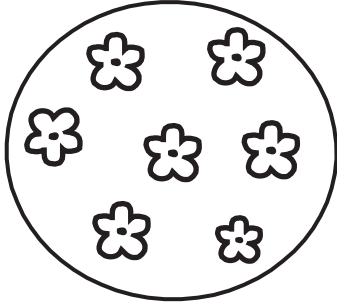

Observa y escribe cuantas patas tiene cada insecto.

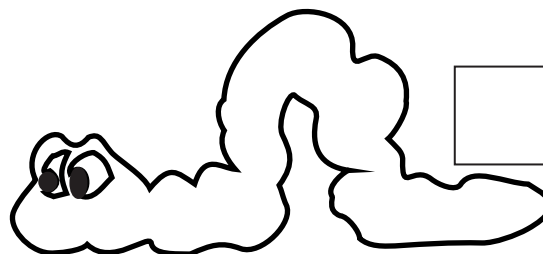
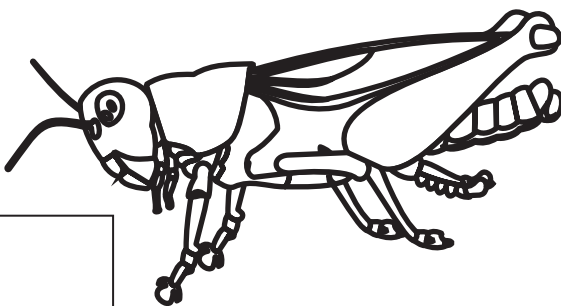
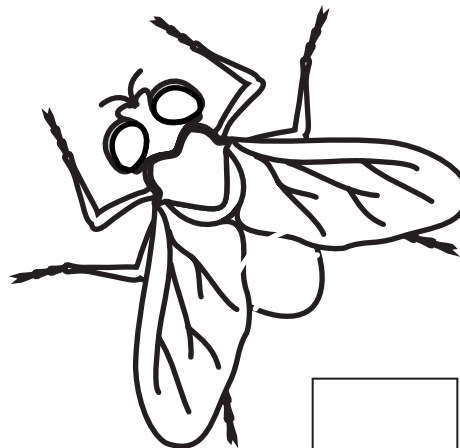
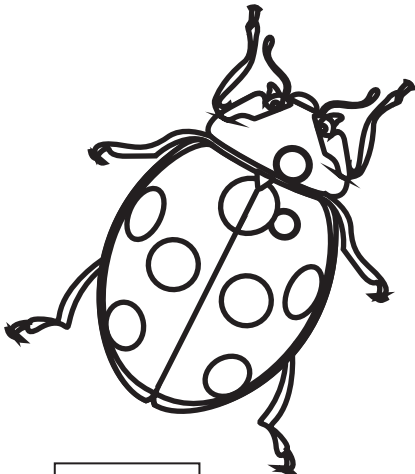
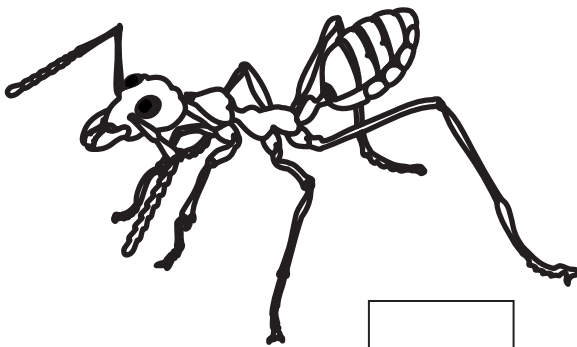
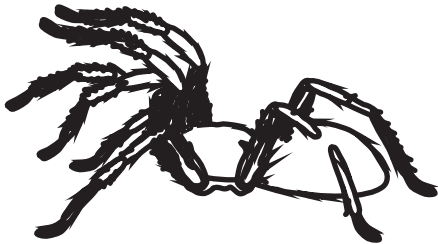

Observa el domino, cuenta los puntos negros y escribe el número en la parte vacía de la figura.

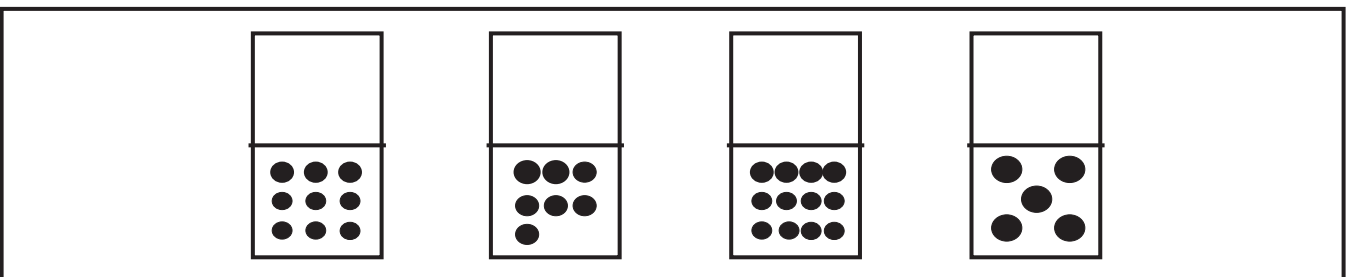
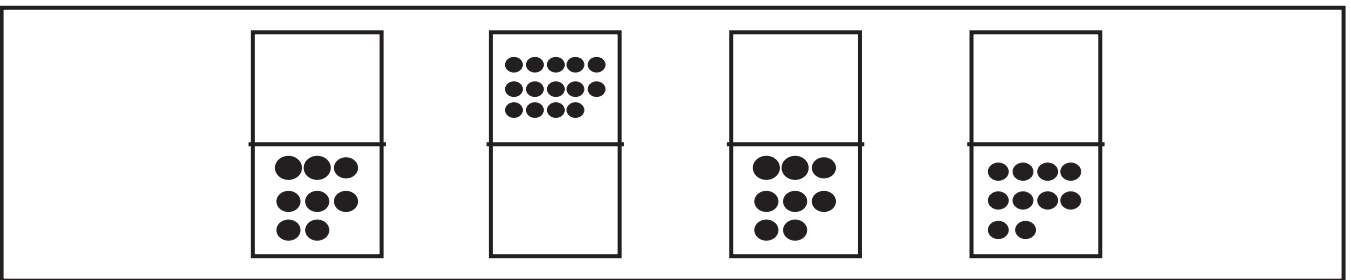
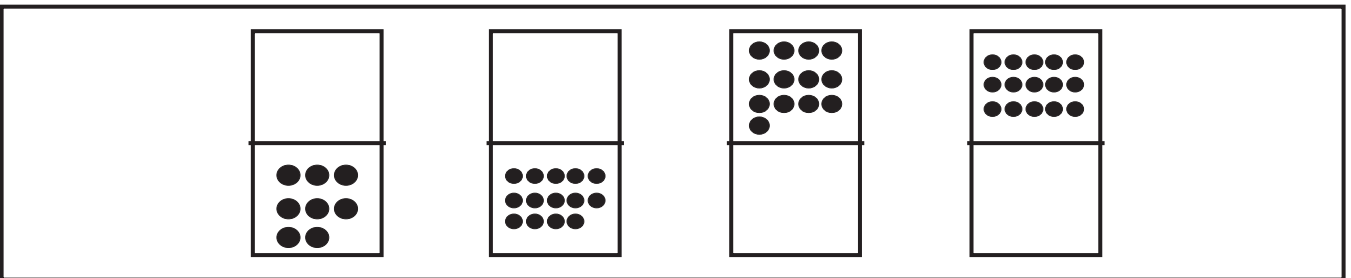
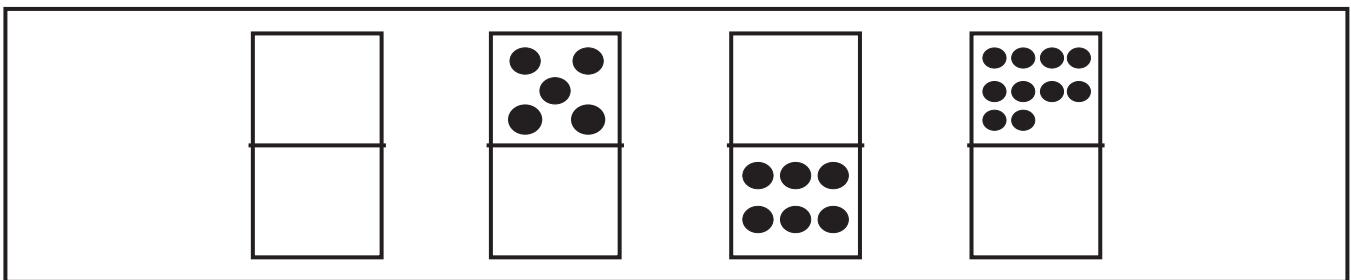
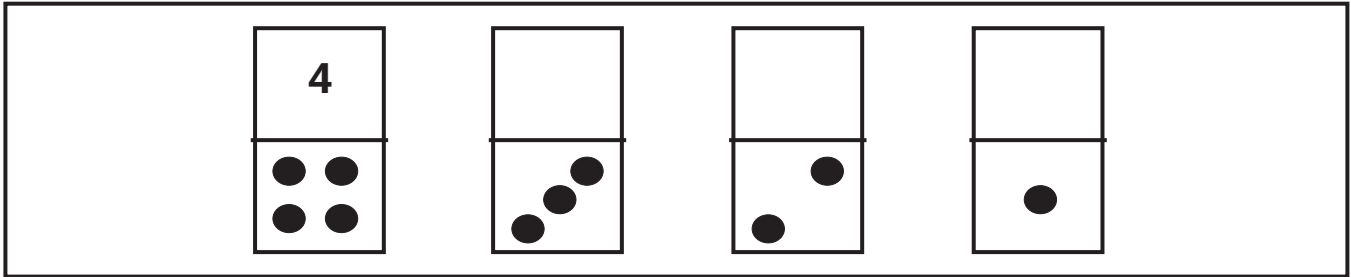

LABERINTO DE CANTIDADES

Traza el camino que lleva a la misma cantidad de elementos. Igual al ejemplo.

The maze consists of five rows of starting points on the left and five rows of ending points on the right. Each starting point contains a set of objects, and each ending point contains a dot matrix. An example path is drawn from the top-left starting point to the top-right ending point.

Row	Starting Point (Left)	Ending Point (Right)
1	8 suns	10 dots (2x5 grid)
2	9 apples	10 dots (2x5 grid)
3	6 leaves	10 dots (2x5 grid)
4	10 soccer balls	10 dots (2x5 grid)
5	8 houses	10 dots (2x5 grid)

Observa y cuenta los dibujos, anota en el recuadro el número según la cantidad de elementos.

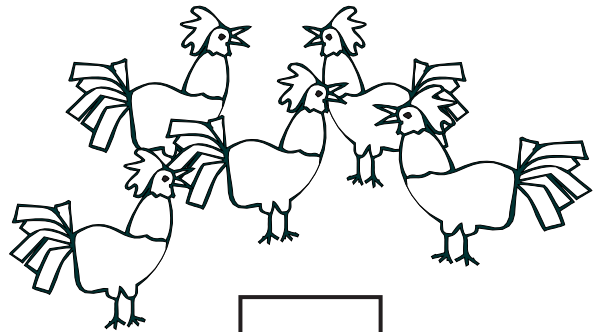
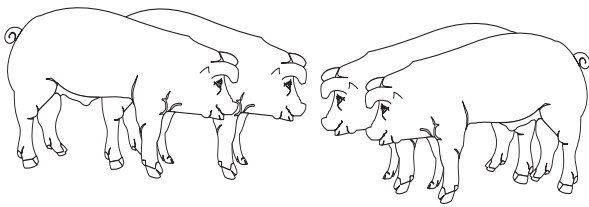
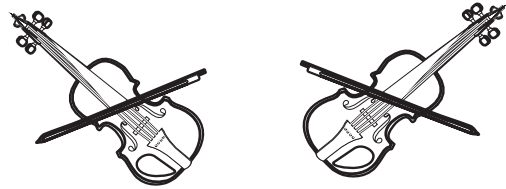
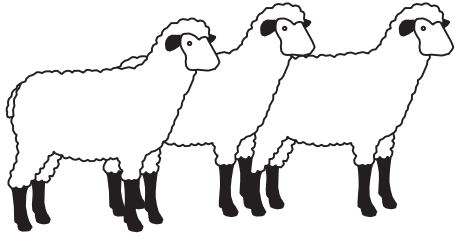

Encierra en un círculo las figuras iguales que aparecen en cada recuadro, según el ejemplo.

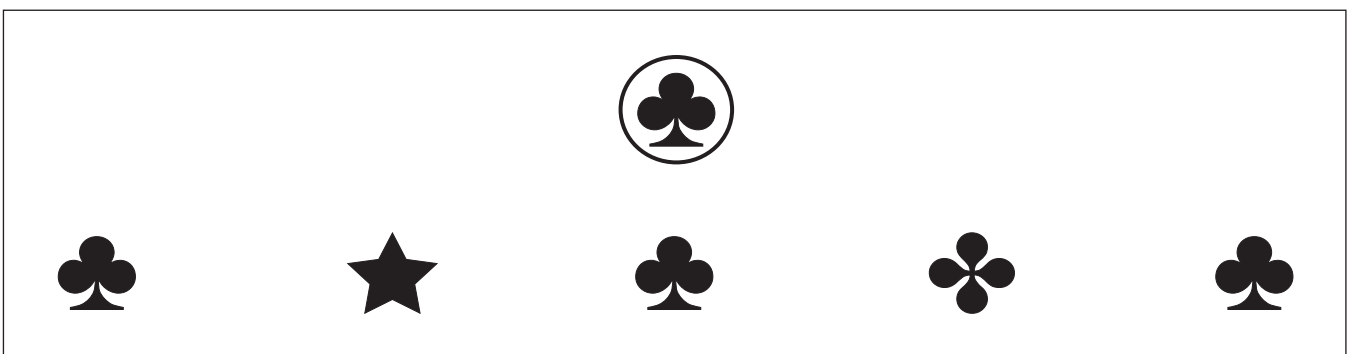
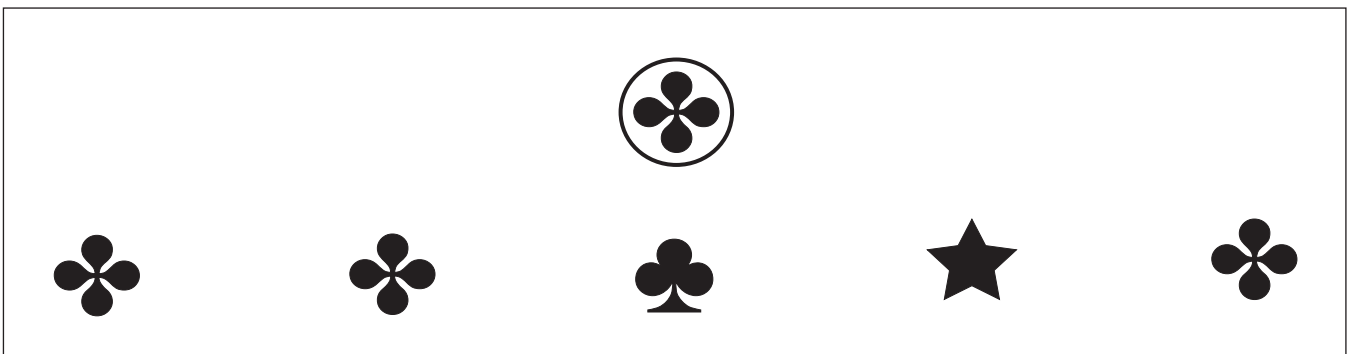
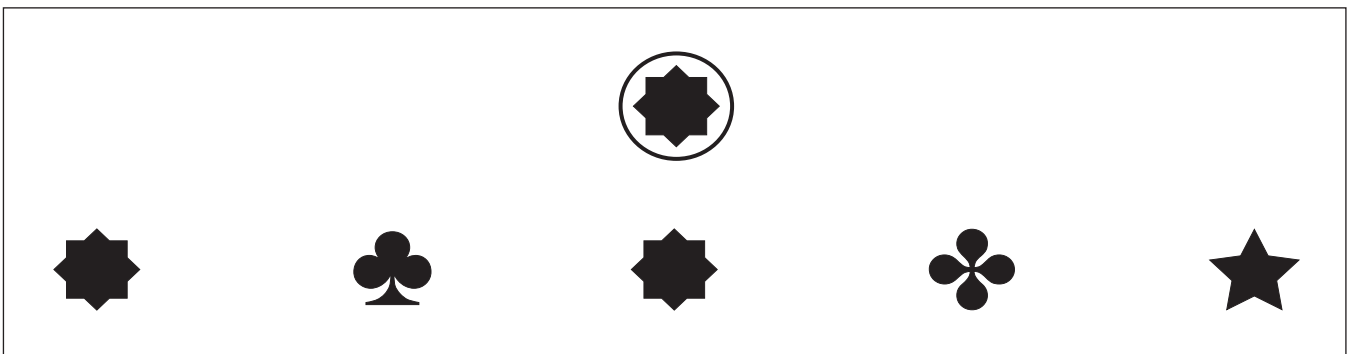
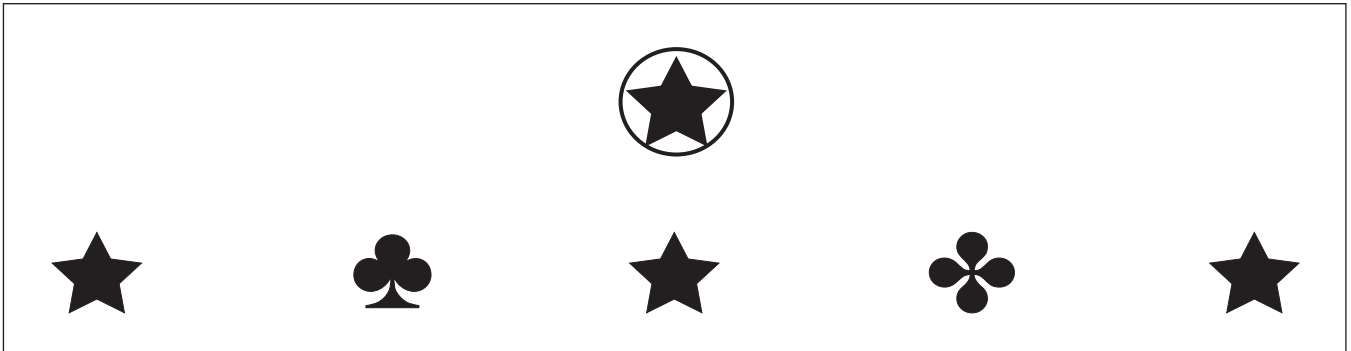

INTRODUCCIÓN AL CÁLCULO

- Cuenta los elementos que tiene cada conjunto de figuras. Escribe el número de elementos en el recuadro de abajo.
- Escribe el total de elementos en el recuadro del lado derecho

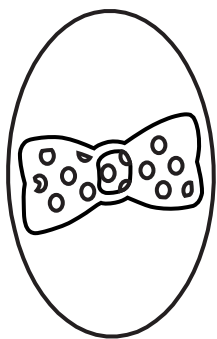

+

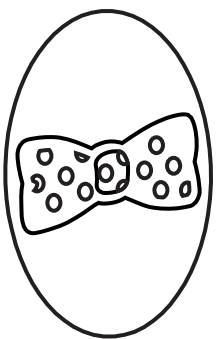

=

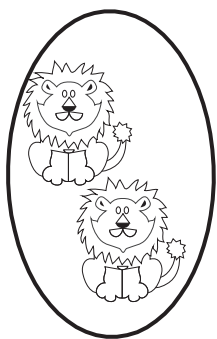

+

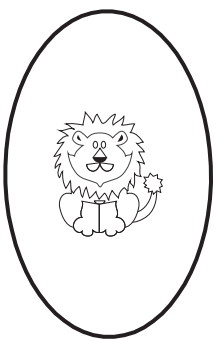

=

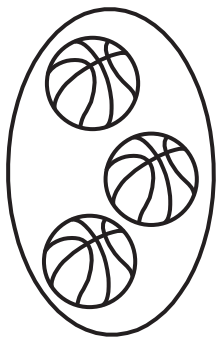

+

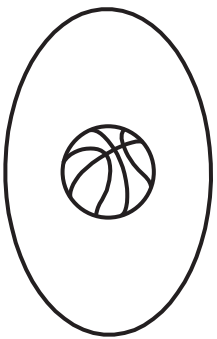

=

IZQUIERDA - DERECHA

Observa la dirección que indican las flechas, colorea de verde la que indica hacia la izquierda y de amarillo la que indica hacia la derecha.

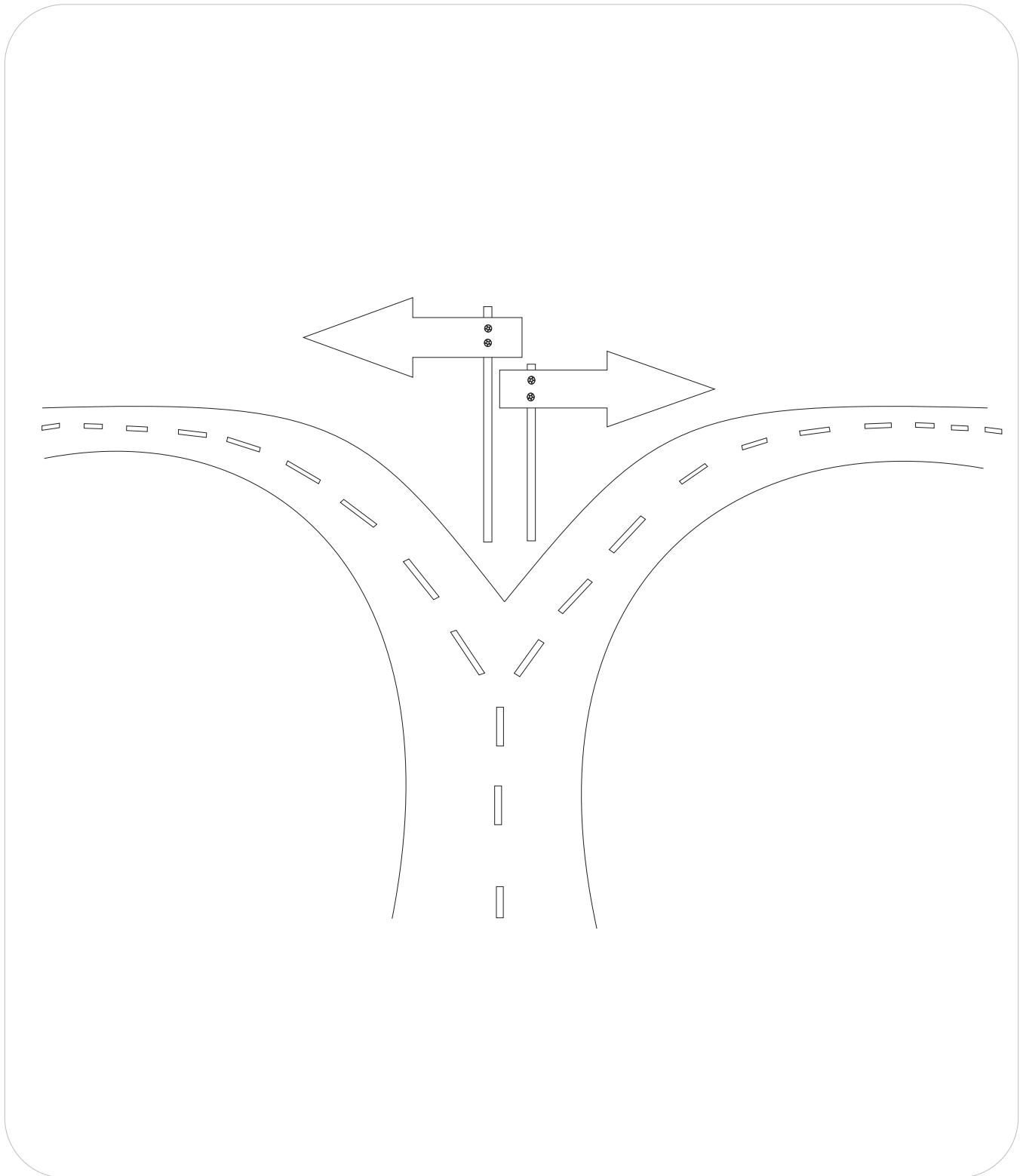

RESTA

- Cuenta los elementos que tiene cada conjunto de figuras. Escribe el número de elementos en el recuadro de abajo.
- Escribe el total de elementos en el recuadro del lado derecho

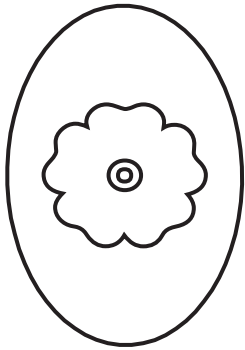

-

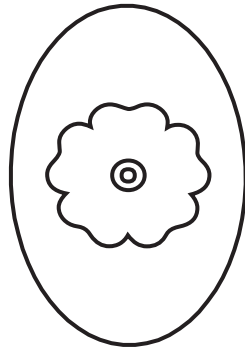

=

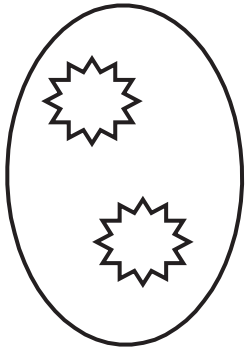

-

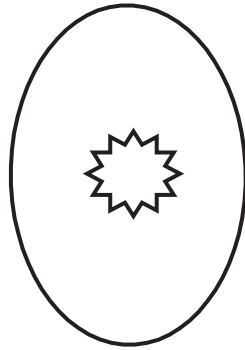

=

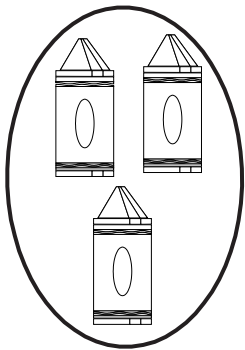

-

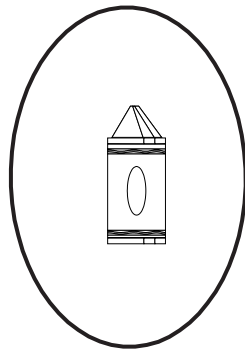

=

RESTA

- Cuenta los elementos que tiene cada conjunto de figuras. Escribe el número de elementos en el recuadro de abajo.
- Escribe el total de elementos en el recuadro del lado derecho

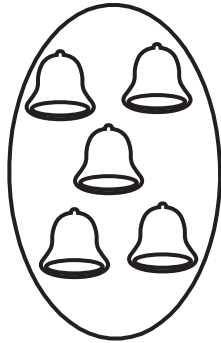

-

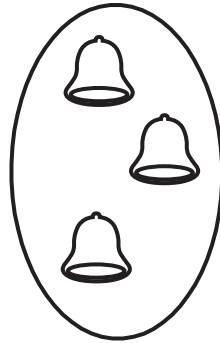

=

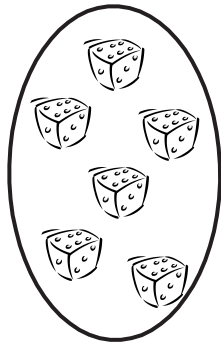

-

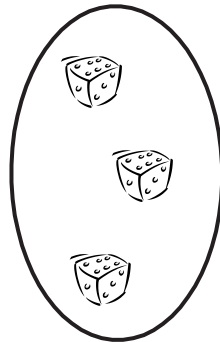

=

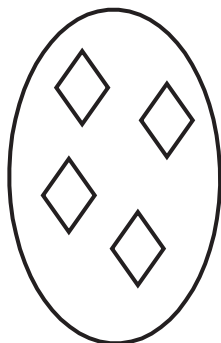

-

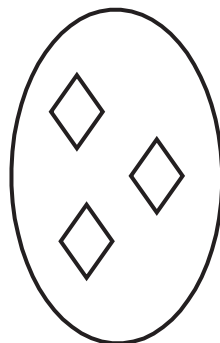

=

Actividad

RESTA

- Cuenta los elementos que tiene cada conjunto de figuras. Escribe el número de elementos en el recuadro de abajo.
- Escribe el total de elementos en el recuadro del lado derecho

A subtraction problem involving dogs. On the left, an oval contains 5 dogs. Below it is a square box. To the right of this oval is a minus sign. Further right is another oval containing 1 dog, with a square box below it. To the right of this second oval is an equals sign, followed by a rectangular box for the answer.

A subtraction problem involving moons. On the left, an oval contains 5 crescent moons. Below it is a square box. To the right of this oval is a minus sign. Further right is another oval containing 1 crescent moon, with a square box below it. To the right of this second oval is an equals sign, followed by a rectangular box for the answer.

A subtraction problem involving cups. On the left, an oval contains 6 cups. Below it is a square box. To the right of this oval is a minus sign. Further right is another oval containing 2 cups, with a square box below it. To the right of this second oval is an equals sign, followed by a rectangular box for the answer.

NÚMEROS ORDINALES

Lee los números ordinales en las primeras dos filas y escribe en las siguientes filas el número ordinal.

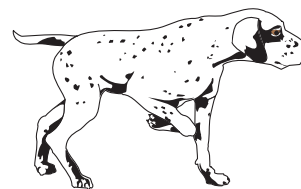
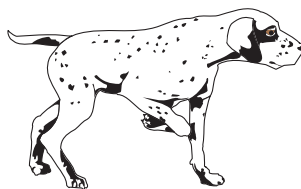
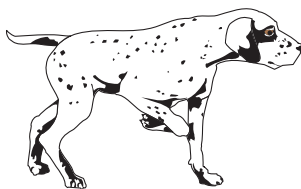
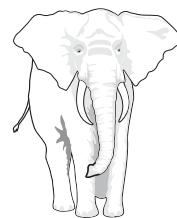
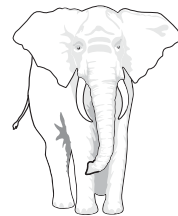
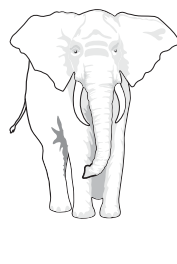
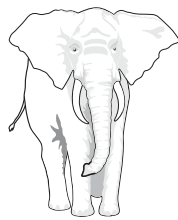
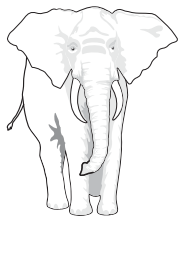
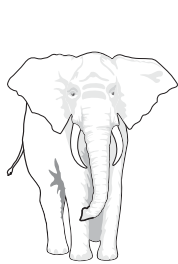
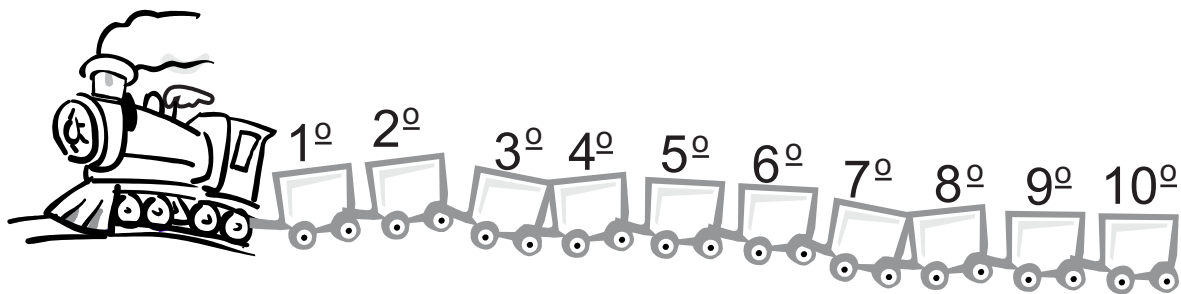
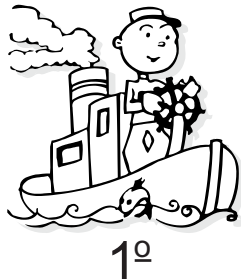

Reproduce las figuras según el ejemplo.

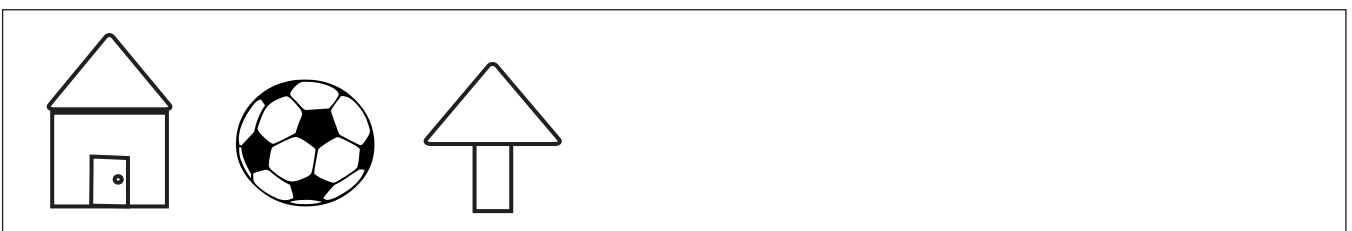
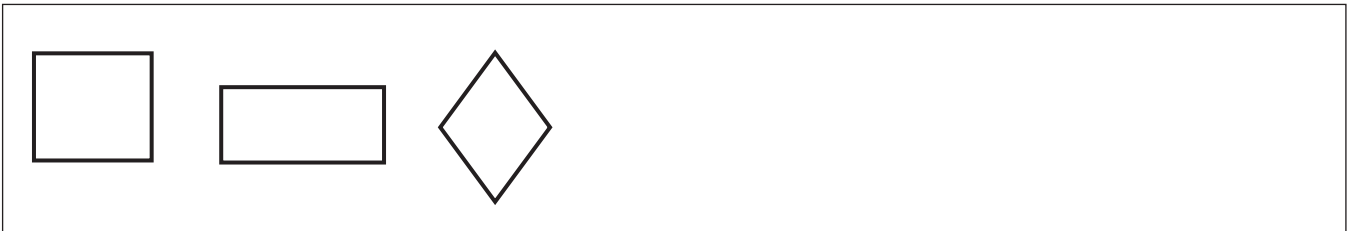
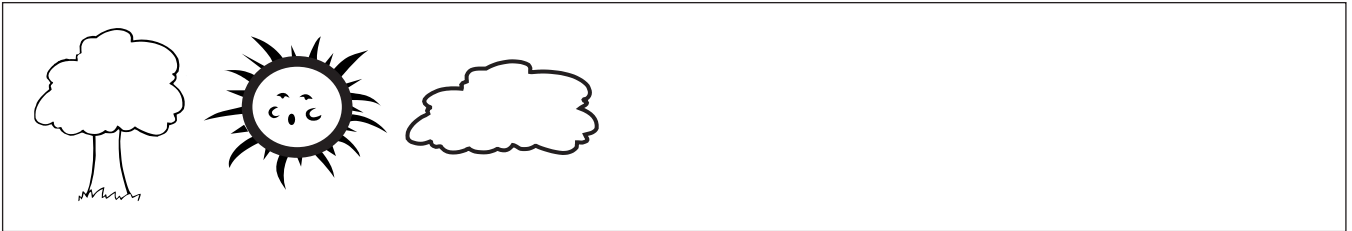
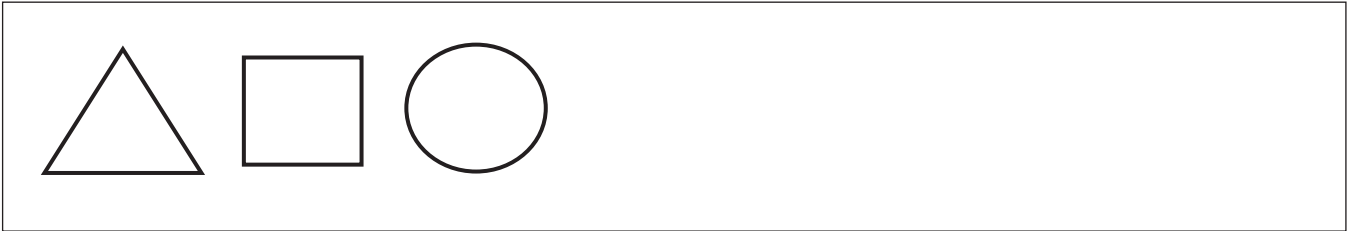

SUMA

- Cuenta los elementos que tiene cada conjunto de figuras. Escribe el número de elementos en el recuadro de abajo.
- Escribe el total de elementos en el recuadro del lado derecho

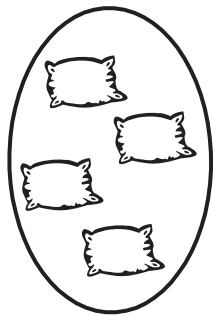

+

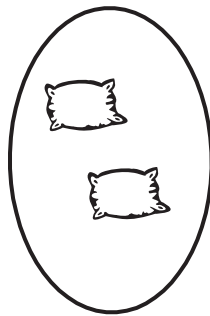

=

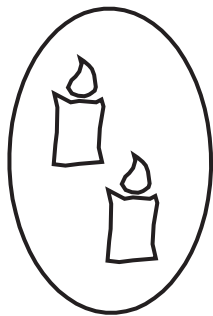

+

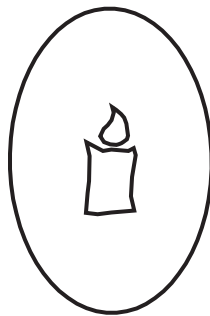

=

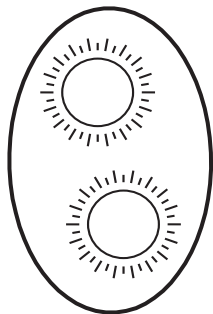

+

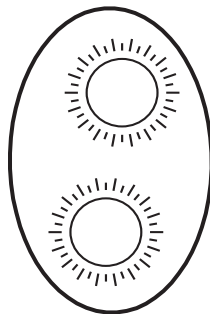

=

Actividad

SUMA

- Cuenta los elementos que tiene cada conjunto de figuras. Escribe el número de elementos en el recuadro de abajo.
- Escribe el total de elementos en el recuadro del lado derecho

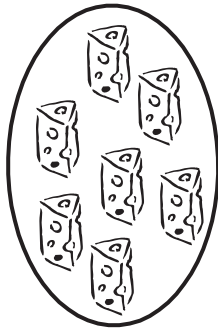

+

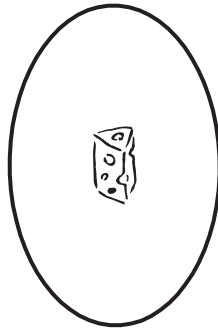

=

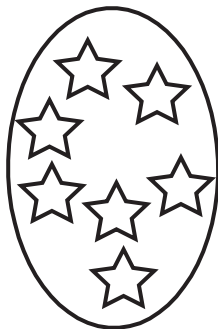

+

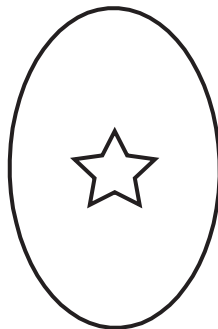

=

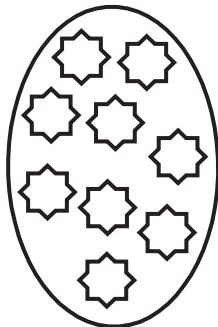

+

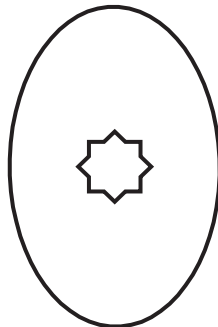

=

Actividad

SUMA

- Cuenta los elementos que tiene cada conjunto de figuras. Escribe el número de elementos en el recuadro de abajo.
- Escribe el total de elementos en el recuadro del lado derecho

4 soccer balls in an oval + 1 soccer ball in an oval =

5 dumplings in an oval + 1 dumpling in an oval =

7 oranges in an oval + 1 orange in an oval =

RESTA

- Cuenta los elementos que tiene cada conjunto de figuras. Escribe el número de elementos en el recuadro de abajo.
- Escribe el total de elementos en el recuadro del lado derecho

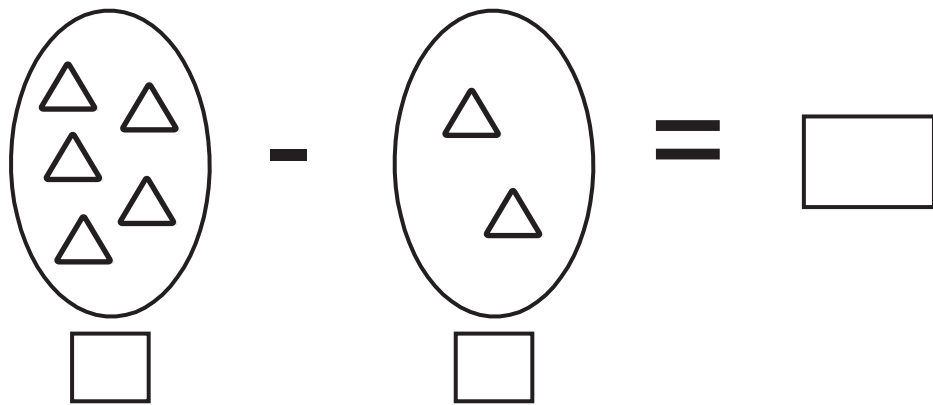
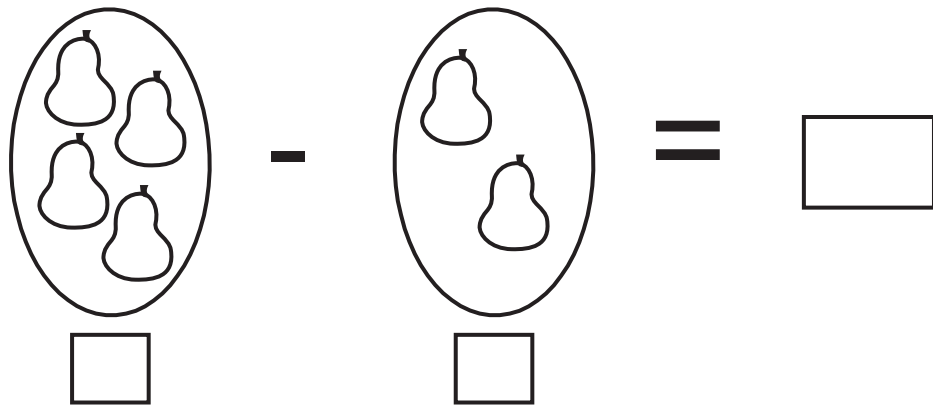
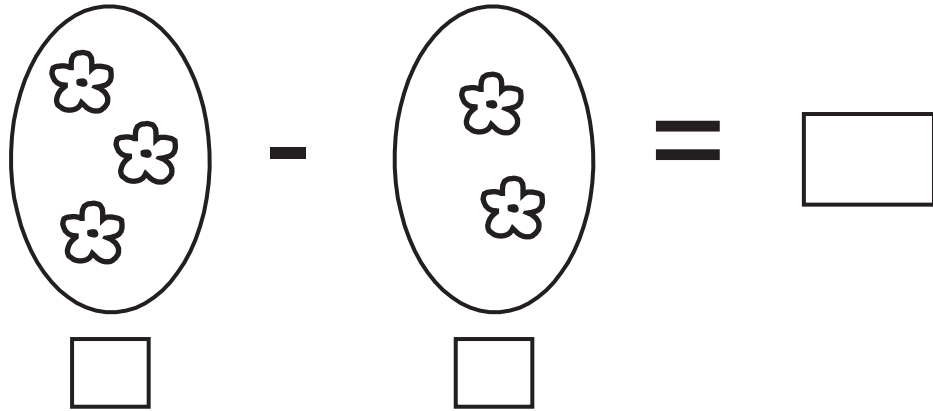

COMPLETACIÓN

Completa coloreando los recuadros según el número, sigue el ejemplo del número uno.

1													
2													
3													
4													
5													
6													
7													
8													
9													
10													

FIGURAS GEOMÉTRICAS

Colorea de rojo el cuadrado, de azul el círculo, de amarillo el triángulo, de anaranjado el rectángulo y de verde el rombo.

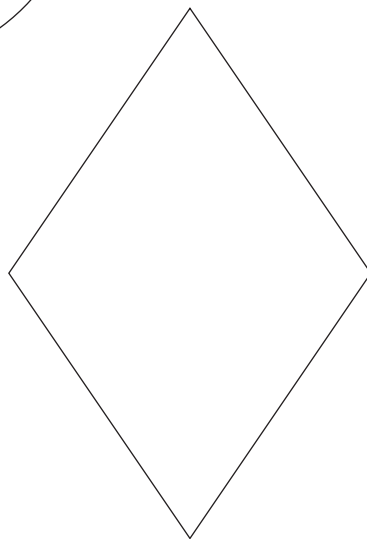
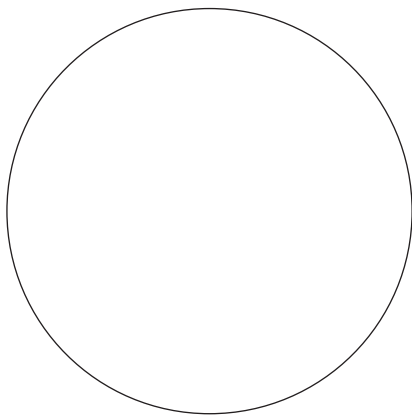
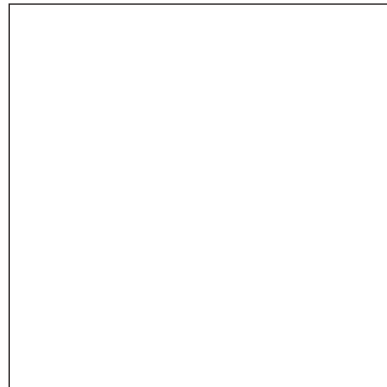
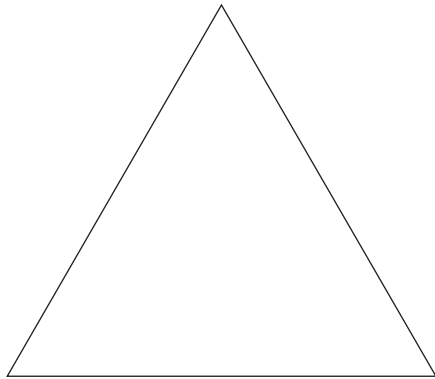

FORMAS

Marca con una "X" los dibujos que tienen forma cuadrada. Colorea los que tienen forma redonda.

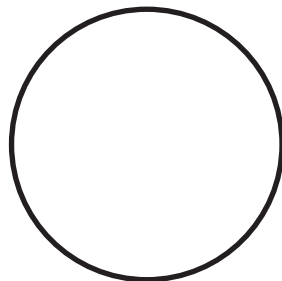
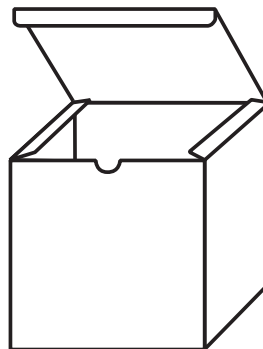
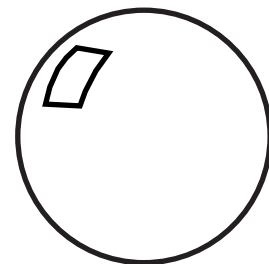
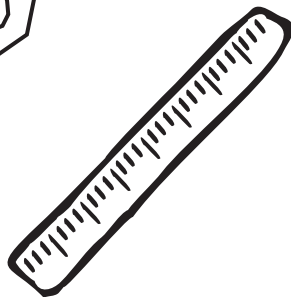
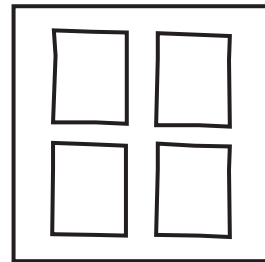
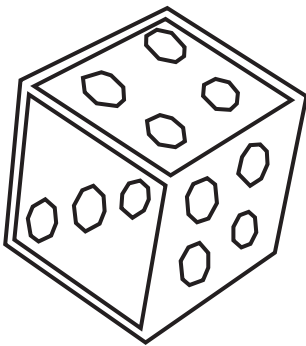
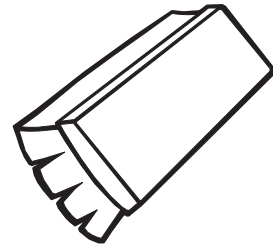
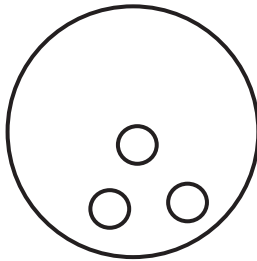
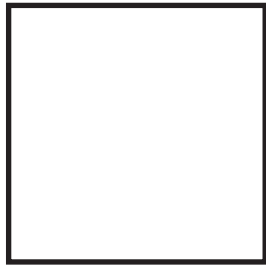

Cuenta las cantidades de cada conjunto de figuras y colorea los que forman una decena.

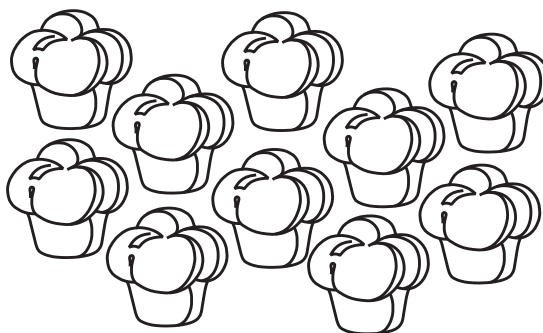
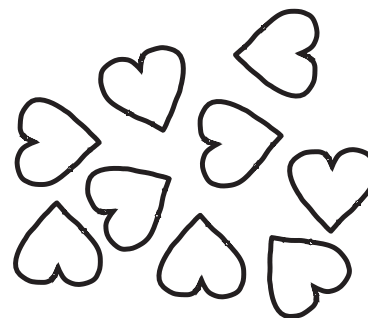
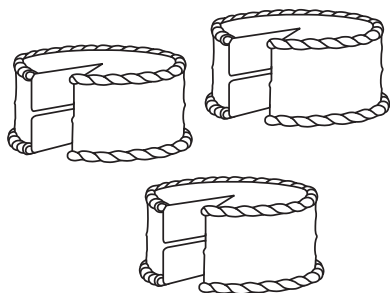
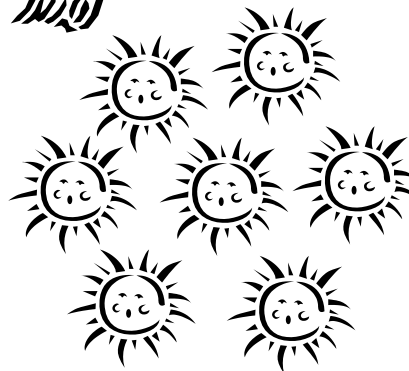
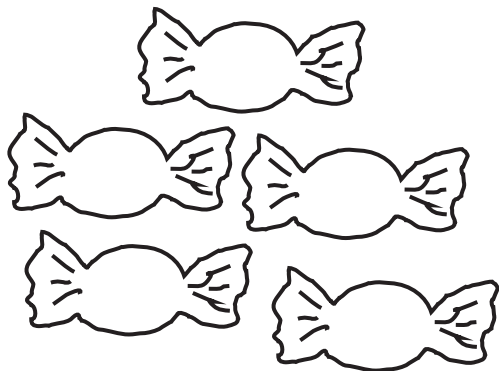
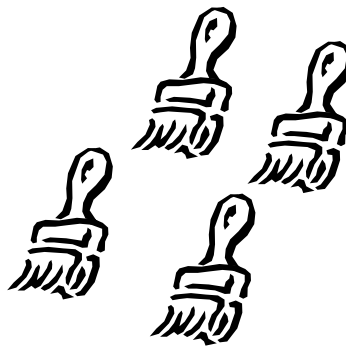
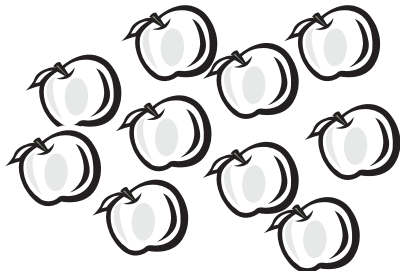

EL RELOJ

Identifica las horas que marcan las manecillas en cada reloj. Escribe las respuestas en el recuadro.

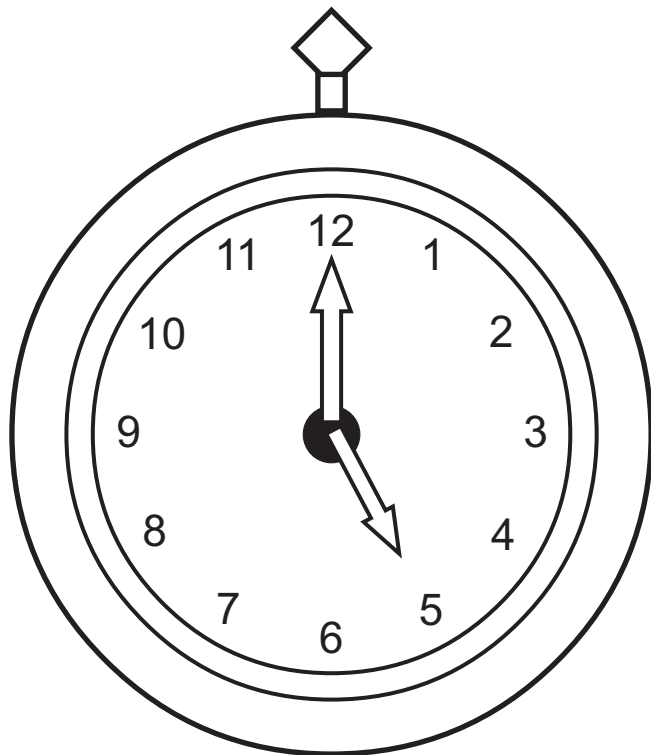

en punto

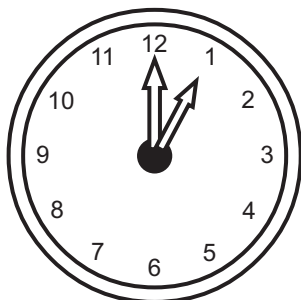

en punto

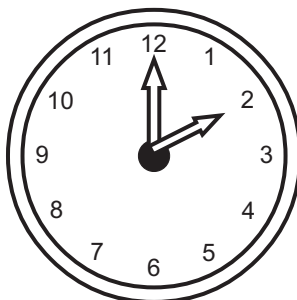

en punto

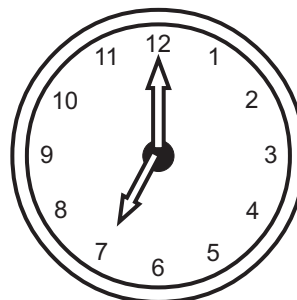

en punto

Identifica las horas indicadas en los relojes y escribe en la línea de abajo la lectura efectuada.

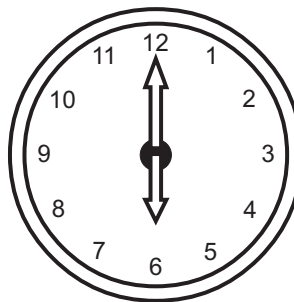
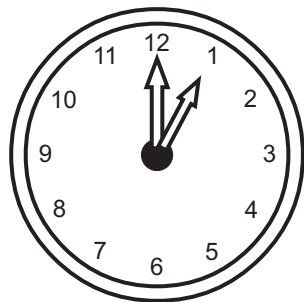
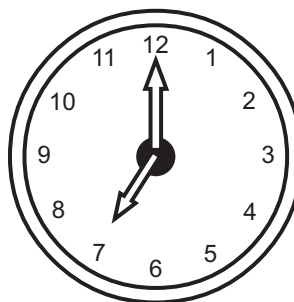
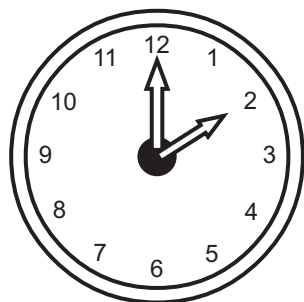
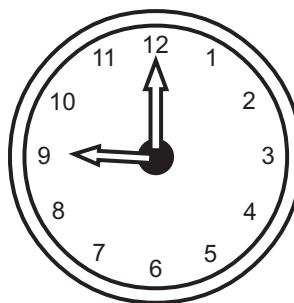
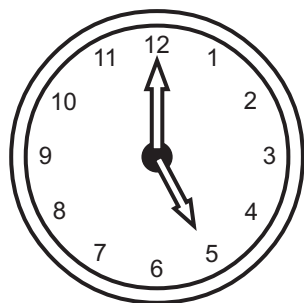

Cuaderno de Trabajo 2
"Juguemos con las Matemáticas"

Impreso en los talleres de _____
Tegucigalpa, M.D.C. _____ de 2014
El tiraje consta de 2,575 ejemplares